

SERVICE MANUAL

Koldfront Free Standing Dual Zone Wine Cooler

MODEL(s):

TWR187ESS

TWR247ESS

**CAUTION: READ ALL SAFETY PRECAUTIONS IN THIS
MANUAL BEFORE SERVICING THE UNIT**

CONTENTS

CONTENTS.....	1
SAFETY PRECAUTIONS	1
ELECTRICAL SAFETY.....	2
GENERAL SAFETY.....	3
THERMOELECTRIC PRECAUTIONS.....	4
FINDING A GOOD SPOT FOR YOUR WINE COOLER	4
THERMOELECTRIC COOLING PRINCIPLES.....	5
EXPLODED VIEW DIAGRAM.....	6
PARTS LIST.....	7
CIRCUIT BOARD DIAGRAM.....	8
SPECIFICATIONS	9
WIRING DIAGRAM.....	9
POWER SUPPLY BOARD.....	10
REPLACING THE POWER SUPPLY BOARD	11
REPLACING THE TEMPERATURE CONTROL BOARD	12
THERMOELECTRIC MODULE AND HEAT FAN.....	13
REPLACING THERMOELECTRIC MODULE AND HEAT FAN.....	13
REPLACING THE COOLING FAN	15
REPLACING THE THERMOELECTRIC NODE	17
ERROR CODES	18
DIAGNOSTICS: WINE COOLER DOES NOT COOL OR WILL NOT RUN.....	19

SAFETY PRECAUTIONS

WARNING: This manual and the information contained herein is intended for use by certified technicians. The manufacturer or seller is not responsible for the interpretation or misuse of the information provided, nor does it assume any liability in connection with its use.

The safeguards and warnings indicated in this manual do not cover all possible conditions which may occur. Common sense, caution, and care must be exercised.

- To prevent electric shock, always unplug an appliance from the power supply before attempting any service.
- Disconnect the power cord by grasping the plug, not the cord.
- Do not bypass, cut, or remove the grounding plug.
- Prevent water from spilling onto electric elements or the machine parts.
- Always refer to the rating label on the appliance for rated current and voltage.
- Always check line voltage and amperage.
- Always use exact replacement parts.
- Any attempt to repair a major appliance may result in personal injury and property damage.

Electrical Safety

- Do not exceed the power outlet ratings.
- It is recommended that the unit be connected to its own circuit.
- A standard electrical supply (120V, 60Hz), that is properly grounded in accordance with the National Electrical Code and all state and local codes and ordinances is required.
- Do not use outlets that can be turned off by a switch or pull chain.
- Always turn the unit off and unplug it from the outlet when cleaning.
- Unplug the unit if it is not going to be used for an extended period of time.
- Do not operate the unit with a power plug missing the ground plug, a damaged cord, or a loose socket.
- Be sure the appliance is properly grounded.
- Do not bypass, cut, or remove the grounding plug.
- If the power cord is damaged, it must be replaced by the manufacturer or a qualified technician.
- Do not use extension cords or power strips with this unit. You may need to contact an electrician if it is necessary to use a longer cord or if you do not have a properly grounded outlet. Do not modify the power cord's length or share the outlet with other appliances.
- Do not start or stop the unit by switching the electrical circuit's power on and off.
- Immediately unplug the unit if it makes strange sounds, emits an odor or smoke and contact customer service.
- Do not remove any part of the casing unless instructed by an authorized technician.
- Before the appliance is removed from service or discarded, remove the door and cut off the power cord.

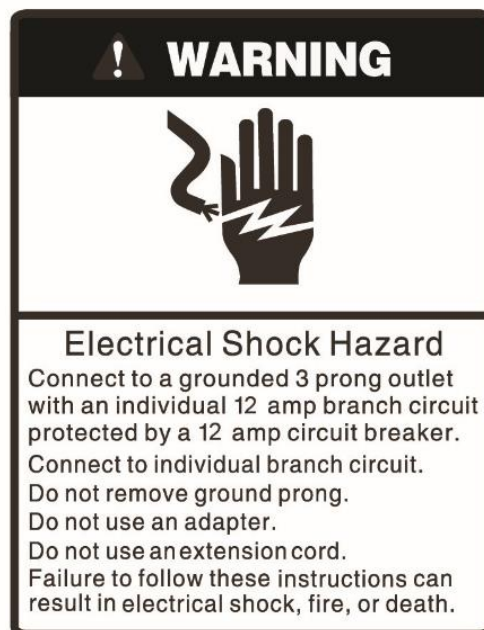
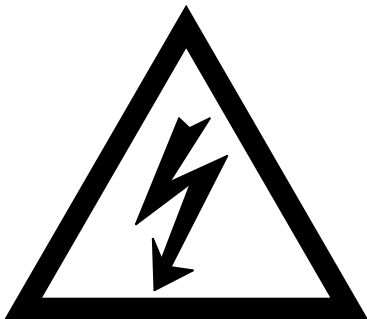

General Safety

- Always unplug an appliance from the power supply before attempting any service. Disconnect the power cord by grasping the plug, not the cord.
- Do not allow children or pets to play on or in the appliance.
- This machine is not intended for use by persons (including children) with reduced physical, sensory or mental capabilities, or lack of experience and knowledge, unless they have been given supervision or instruction concerning use of the machine by a person responsible for their safety.
- Do not install or store this appliance where it will be exposed to the weather.
- Disconnect from the power socket before cleaning or maintenance.
- If the plug (power cord) is damaged, it must be replaced by the manufacturer or an authorized service representative.
- This machine shall be repaired only by an authorized service representative. Only genuine replacement parts should be used.
- If connected to a circuit protected by fuses, use time-delay fuses with this appliance.
- Do not lean items against the glass door.
- Please do not close the door with excessive force. If it is found difficult to close the door, please check for obstruction.
- When you plan to dispose of this unit in the future, please comply with the local waste disposal regulations. Remove the door so that children and pets will not be trapped in the unit.

Thermoelectric Precautions

This wine cooler uses thermoelectric technology rather than compression or absorption-types and there are several issues that need attention:

- Room temperature - The wine cooler needs to be located in a climate controlled room. The unit will perform it's best at a room temperature of approximately 72° to 77°F. It will not cool correctly when the room temperature is higher than 90° or lower than 65°F.
- Ventilation – The wine cooler needs to be free standing. It should not be recessed or built in (fully recessed.) Allow enough clearance (5”) at the rear and sides of the wine cooler to allow proper ventilation. Lack of proper ventilation will have a negative impact on the performance of cooler.
- Moisture – The wine cooler may have some condensed water on the surface of the glass door if opened constantly in a moist place. This moisture will drain into the condensate tray at the back of the unit and may require emptying if excessive moisture is collected in a short period of time.

Finding a good spot for your wine cooler

Where you locate the wine cooler is critical to its performance. Follow these guidelines:

- Install your wine cooler on a level surface that is strong enough to support it when fully loaded.
- Allow 5 inches (15cm) of space at the rear and at both sides of the wine cooler to allow proper ventilation.
- This wine cooler is designed to be free standing only and should not be recessed or built-in (fully recessed.)
- Do not place heavy objects on top of the unit.
- Do not install the unit outside or in a moist place.
- Do not install the wine cooler in direct sunlight or next to heat sources.
- The unit's cooling system operates at maximum efficiency with an ambient room temperature of 72° to 77°F. The interior temperature can be set between 44°F and 66°F and will be most accurate in that temperature range.

Thermoelectric Cooling Principles

Thermoelectric cooling, called the Peltier effect, is a solid-state method of cooling or heating by passing current through two different (P shape & N shape) semiconductor materials.

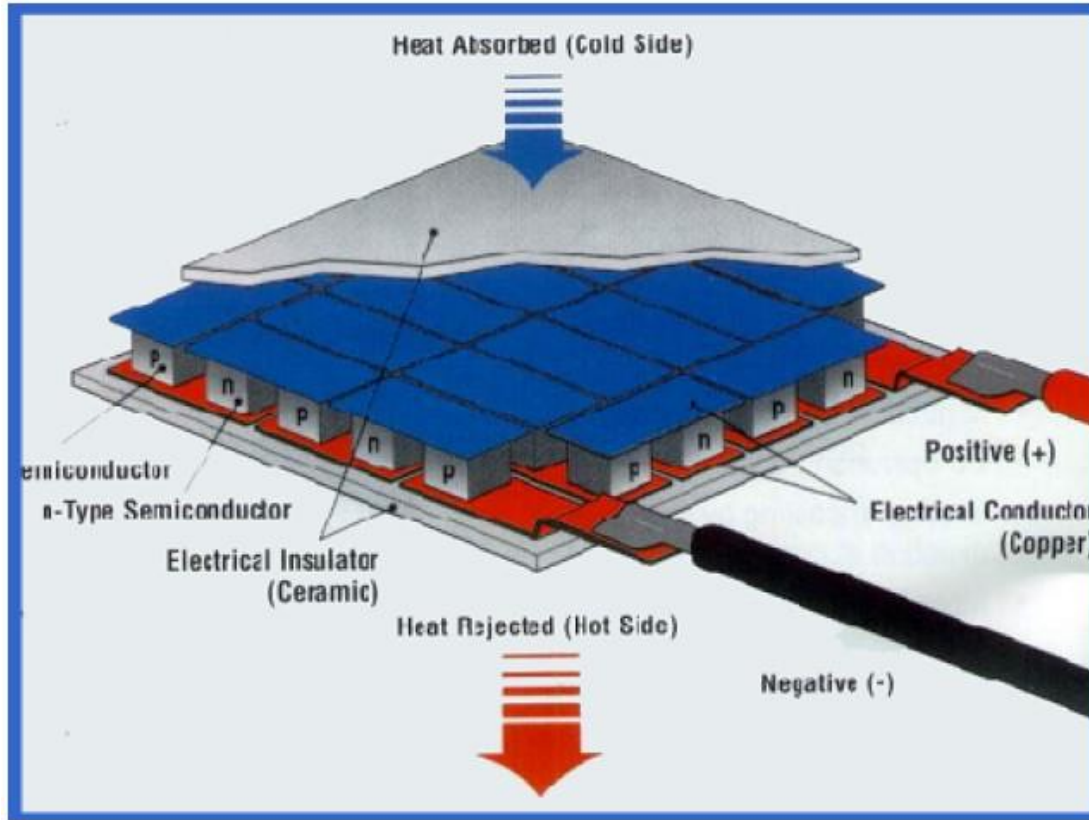

The complete system includes a semi-conductor module (P&N shape semi-conductors clamped with two ceramic chips), an internal and external heat exchanger. To obtain higher energy efficiency low-speed-and-noise fans are fitted to the heat exchangers. During operation direct current goes through the semiconductor module which causes heat to be transferred from one side to the other.

Exploded View Diagram

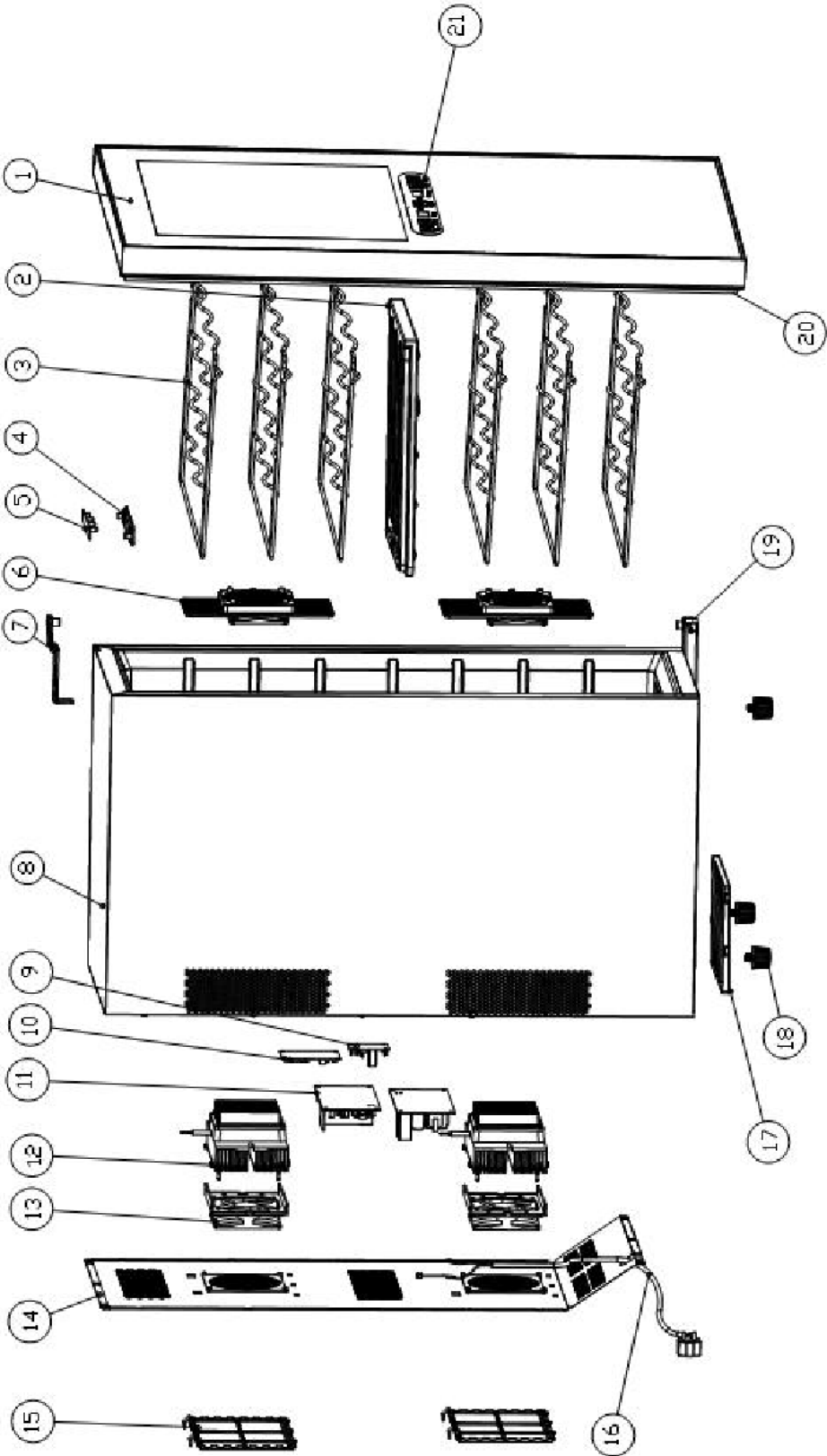

Parts List

No.	Part Name
1	Door
2	Zone Board
3	Wine Bottle Shelf
4	Light cover
5	Light
6	Cooling fan
7	Upper hinge
8	Cabinet
9	Temperature Control Board
10	Distributer Plate
11	Power Supply Board
12	Thermoelectric Module
13	Heating fan
14	Back cover
15	Dust Filter
16	Power cord
17	Condensate Try
18	Leveling Leg
19	Lower Hinge
20	Door Seal
21	Temperature Control Display

Circuit Board Diagram

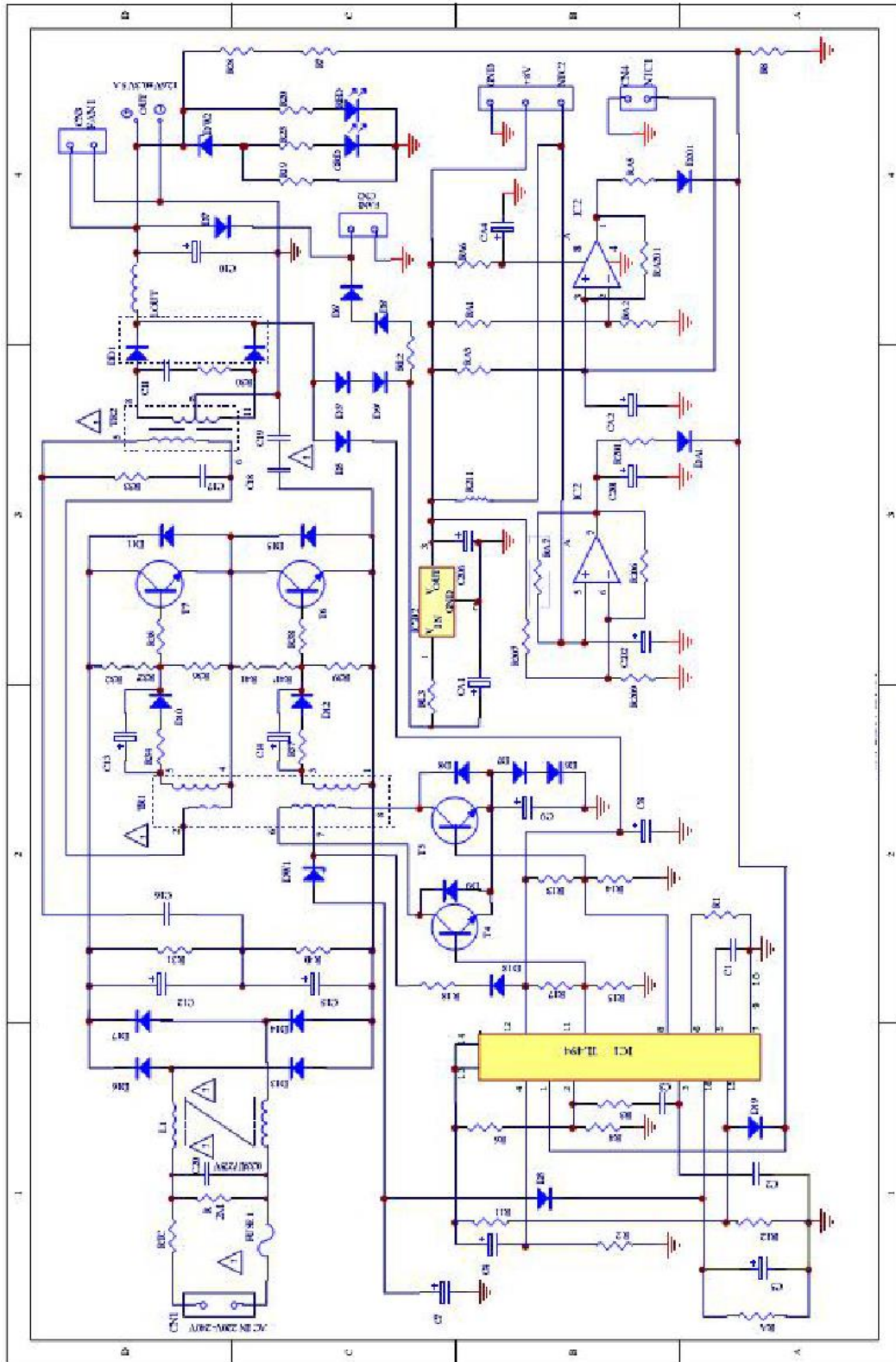

Specifications

Model	TWR187ESS
Voltage/Frequency	115V/60Hz
Power	110W
Rated Current	1.0A
Net Weight	35.3 lbs.

Model	TWR247ESS
Voltage/Frequency	115V/60Hz
Power	100W
Rated Current	1.4A
Net Weight	39 lbs.

Note: Specifications are subject to change. Check the rating label on the back of unit for the most accurate information

Wiring Diagram

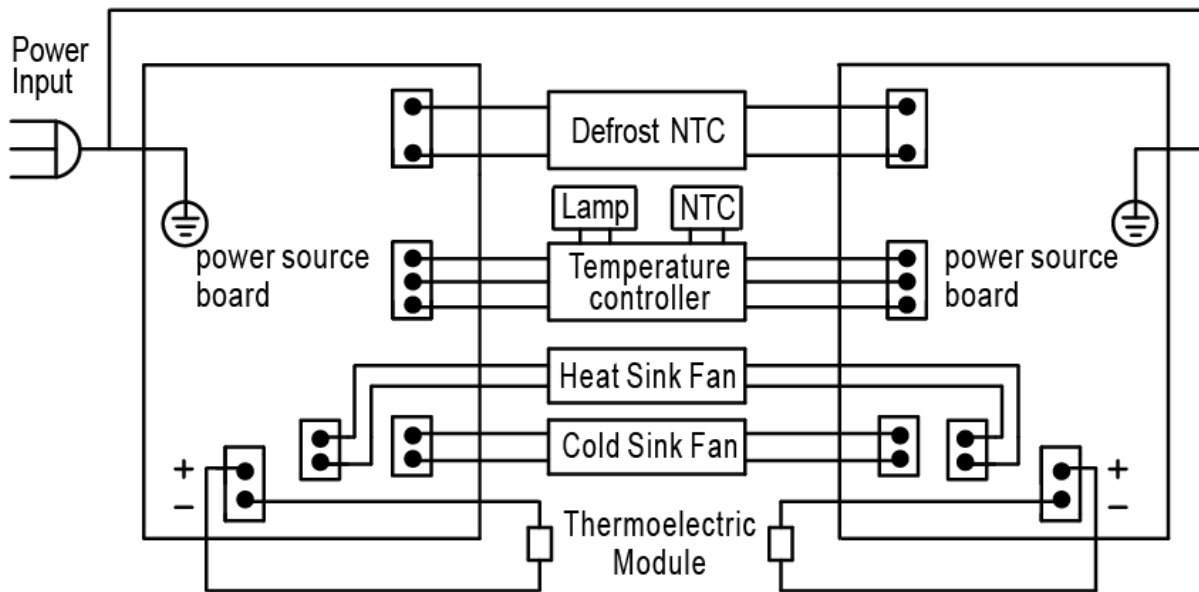

Power Supply Board

Connector Arrangement



- 1.Power Cord
- 2.Thermoelectric Module
- 3.Heating Fan
- 4.Cooling Fan
- 5.Temperature Controller
- 6.Temperature Sensor

Replacing the Power Supply Board

1. Remove the rear cover, disconnect the wire connectors on the Power Supply Board and replace with new board.

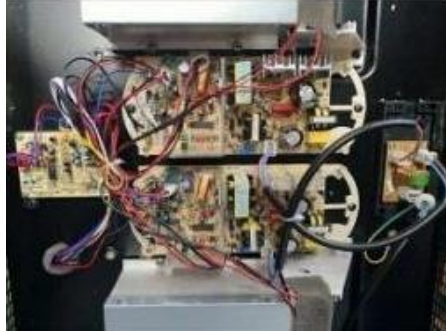

2. Reconnect the connectors on the Power Supply Board







3. Reconnect the connectors on the Power Junction Board



4. Reconnect the connectors on the Temperature Control Board



Replacing the Temperature Control Board

 <p>1.Remove the door seal.</p>	 <p>2.Remove screws (2) from the rear of the door.</p>
 <p>3. Remove the screws (2) from the temperature controller box then disassemble the door frame.</p>	 <p>4. Pull out the temperature controller, disconnect the wire connector and replace with new controller.</p>
 <p>5.Reconnect the wire connector.</p>	 <p>6. Reattach the door and replace the seal.</p>

Thermoelectric Module and Heat Fan

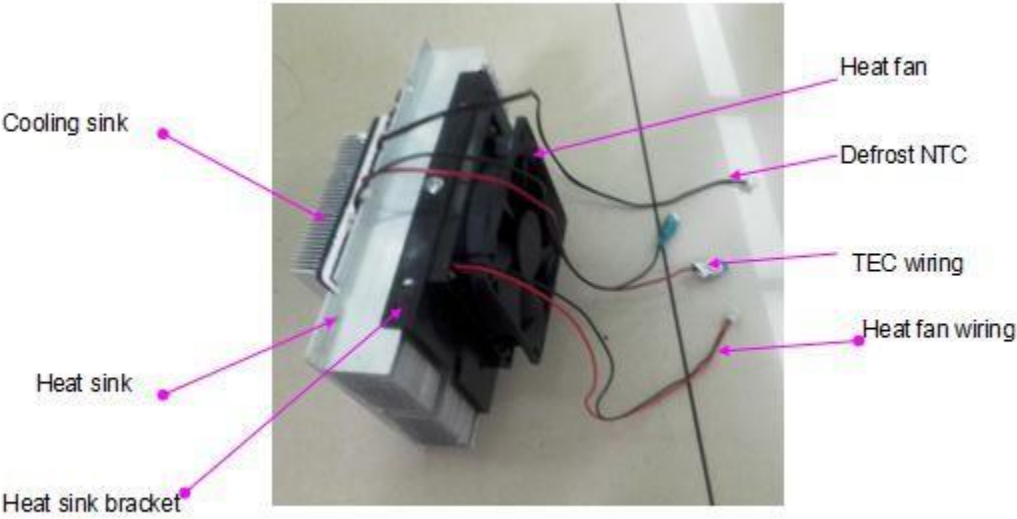

Replacing Thermoelectric Module and Heat Fan

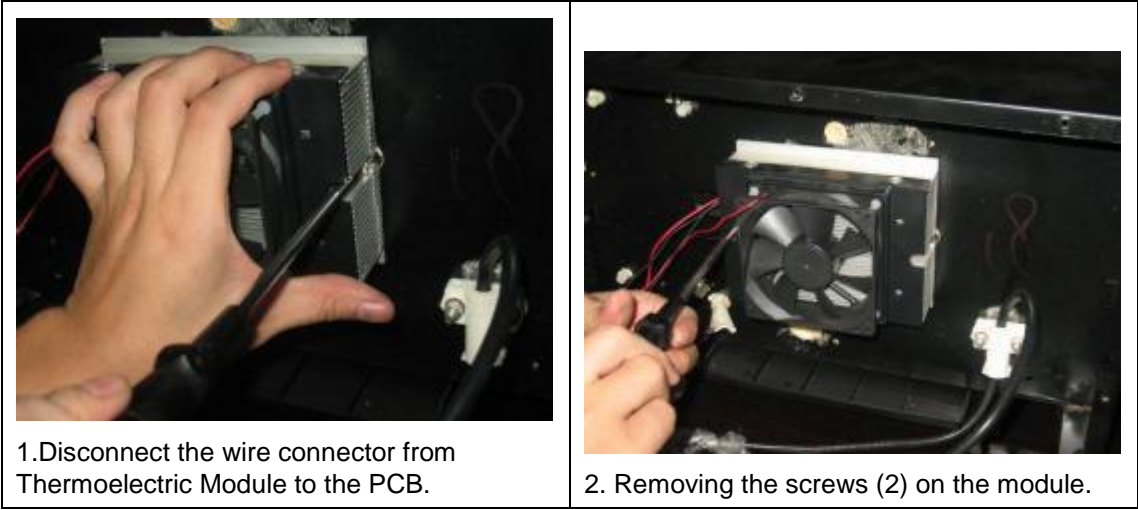



3. Pull out the module.



4. Remove the screws (4) from the two sides of heat sink



5. Replace the heat fan.



6. Reattach the screws (4)



7. Put bracket into the proper position and reattach the screws (2) on the module.



8. Reconnect the wire connectors with PCB.

Replacing the Cooling Fan



1. Pull out the plastic caps (4) on the cooling fan cover.



2. Removing the screws (4) on the cooling fan cover.



3. Disconnect the wire connector after opening the cooling fan cover.



4. Remove the screws (4) from the cooling fan.



5. Replace the old cooling fan and reconnect the wire.



6. Be careful not to damage the wire.



7. Fix the sensor into the proper position.



6. Reattach the caps (4) and screws (4).

Replacing the Thermoelectric Node

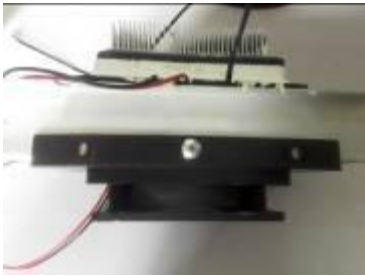

1. Remove the screws to remove the heat fan subassembly

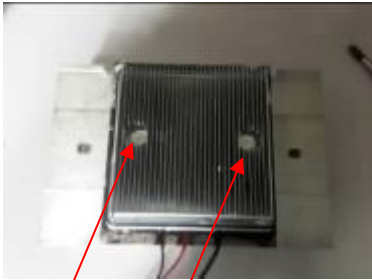

2. Remove two (2) screws



3. Disassemble heat sink



4. Remove old node and apply thermal grease evenly on new node.

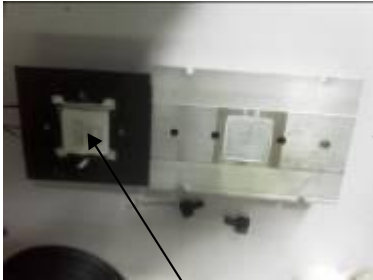



5. Replace the thermoelectric node in the correct direction. The heat side of the node has printing on it.



6. Reassemble the heat sink and heat fan subassembly.

Error Codes

Model No.	Error Code				Meaning of Error code	
					Lo/L	Er/E
TWR187ESS & TWR247ESS	Lo		Er		The temperature sensor has open circuit.	The temperature sensor has short circuit.

Diagnostics: Wine cooler does not cool or will not run.

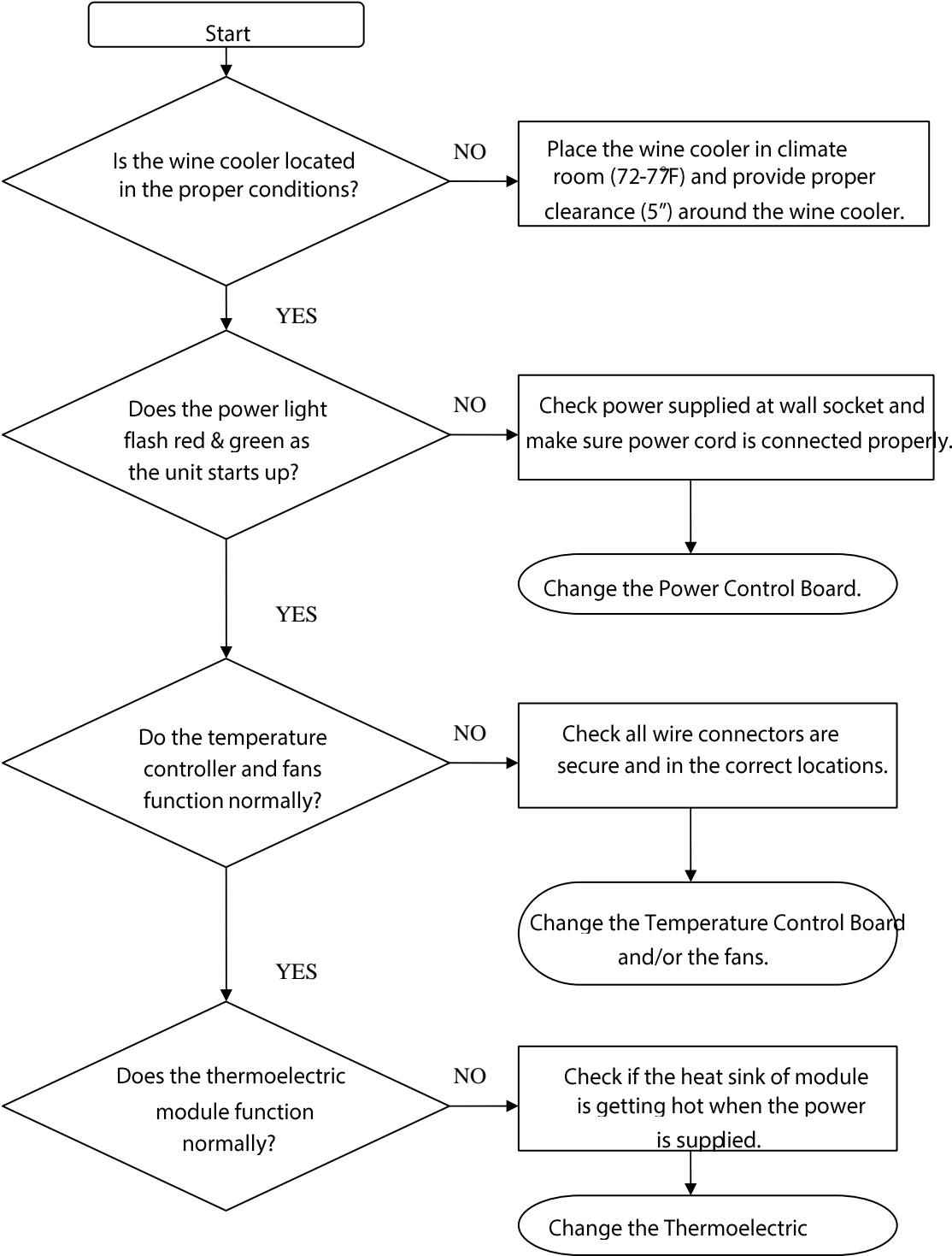

DATE	REVISION NOTES
02/05/2018	INITIAL DOCUMENT