

## EdgeStar Dehumidifier Filter Cleaning

On a regular basis it is required that the filter be inspected for buildup of lint, dust and other materials. A clogged filter can restrict proper airflow and cause undue strain on the mechanical components of your dehumidifier resulting in reduced performance and shorter product lifespan.

**NOTE: *Never operate your dehumidifier without the filter properly installed.***

Clean the filter periodically to prolong the unit's life, and keep the unit running efficiently. Lint, dust, and dirt can clog the unit and reduce its performance and effectiveness. If the unit is used in a dusty environment you may need to clean the filter on a weekly basis.

### To clean the filter, follow the steps below:

1. Power the unit off and remove the filter.
2. Use a vacuum cleaner or gently tap the filter to remove loose dust and dirt and then rinse thoroughly under lukewarm water (below 104°F). You may use a mild soap and water solution as needed.
3. Allow the filter to dry thoroughly in a cool shaded place.
4. Reinstall the filter.

**\*\*DO NOT attempt to clean the filter in a dishwasher. Doing so will damage the filter material.**

### Filter Location:

Models DEP500WP and DEP700WP

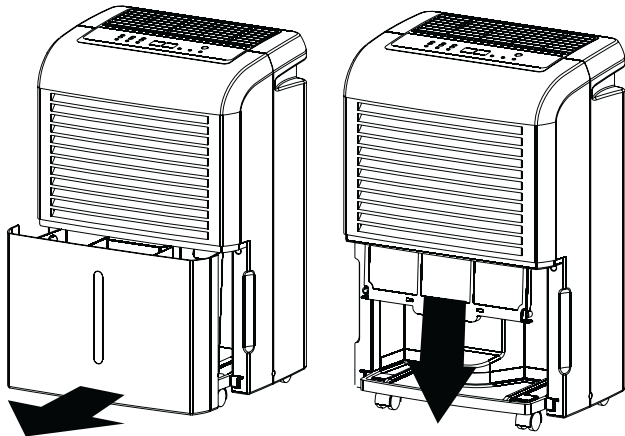

Models DEP301ES, DEP501ES, DEP701ES

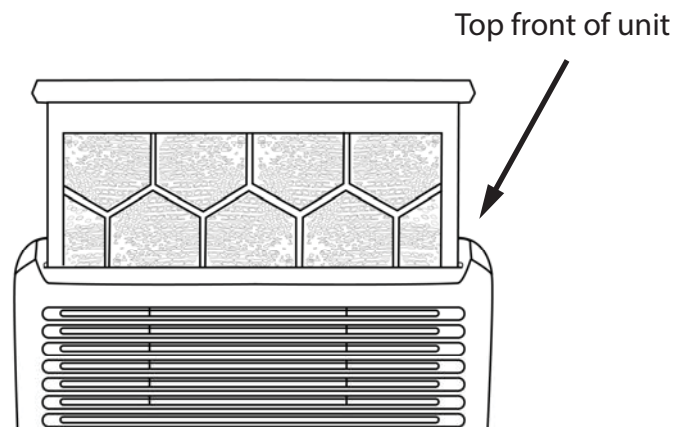

For additional help, support videos and troubleshooting tips, please visit EdgeStar support at [www.edgestar.com](http://www.edgestar.com)