

# SERVICE MANUAL

## Single Zone Cooler

### MODEL:

AFR151SSOD, AFR151SS, ABR151SG, AWC151SZ, ABR241SG,  
AWC241SZ, AFR241SS, AFR241SSOD, AWC241TSZ, AWC241FD

**CAUTION: READ ALL SAFETY PRECAUTIONS IN THIS  
MANUAL BEFORE SERVICING THE UNIT**

# CONTENTS

---

<b>SAFETY PRECAUTIONS</b> .....	<b>2</b>
<b>PARTS IDENTIFICATION</b> .....	<b>3-12</b>
<b>DISASSEMBLY</b> .....	<b>12-19</b>
<i>DOOR</i> .....	12
<i>GLASS SHELVES</i> .....	13
<i>WIRES SHELVES</i> .....	13-14
<i>TOP LAMP</i> .....	14
<i>BROADSIDE LAMP</i> .....	14
<b>COLD CATALYST SYSTEM</b> .....	14
<i>DISPLAY BOARD BOARD &amp; CONTROL BOARD</i> .....	15
<i>POWER BOARD &amp; TRANSFORMER</i> .....	15
<i>SENSOR &amp; FAN</i> .....	16-18
<i>COMPRESSOR PTC STARTER &amp; OVERLOAD PROTECTOR</i> .....	18
<b>TROUBLESHOOTING</b> .....	<b>20-23</b>
<i>COMPRESSOR COMPONENTS</i> .....	20
<i>ANOTHER ELECTRIC COMPONENT</i> .....	21
<i>SERVICE DIAGNOSIS CHART</i> .....	22
<i>REFRIGERATING CYCLE</i> .....	23
<b>DESCRIPTION OF PCB</b> .....	<b>24</b>

# SAFETY PRECAUTIONS

---

**WARNING:** This manual and the information contained herein is intended for use by certified technicians. The manufacturer or seller is not responsible for the interpretation or misuse of the information provided, nor does it assume any liability in connection with its use.

The safeguards and warnings indicated in this manual do not cover all possible conditions which may occur. Common sense, caution, and care must be exercised.

- To prevent electric shock, always unplug an appliance from the power supply before attempting any service.
- Disconnect the power cord by grasping the plug, not the cord.
- Do not bypass, cut, or remove the grounding plug.
- Prevent water from spilling onto electric elements or the machine parts.
- Always refer to the rating label on the appliance for rated current and voltage.
- Always check line voltage and amperage.
- Always use exact replacement parts.
- Any attempt to repair a major appliance may result in personal injury and property damage.

# 2. PARTS IDENTIFICATION

Model: AFR151SSOD

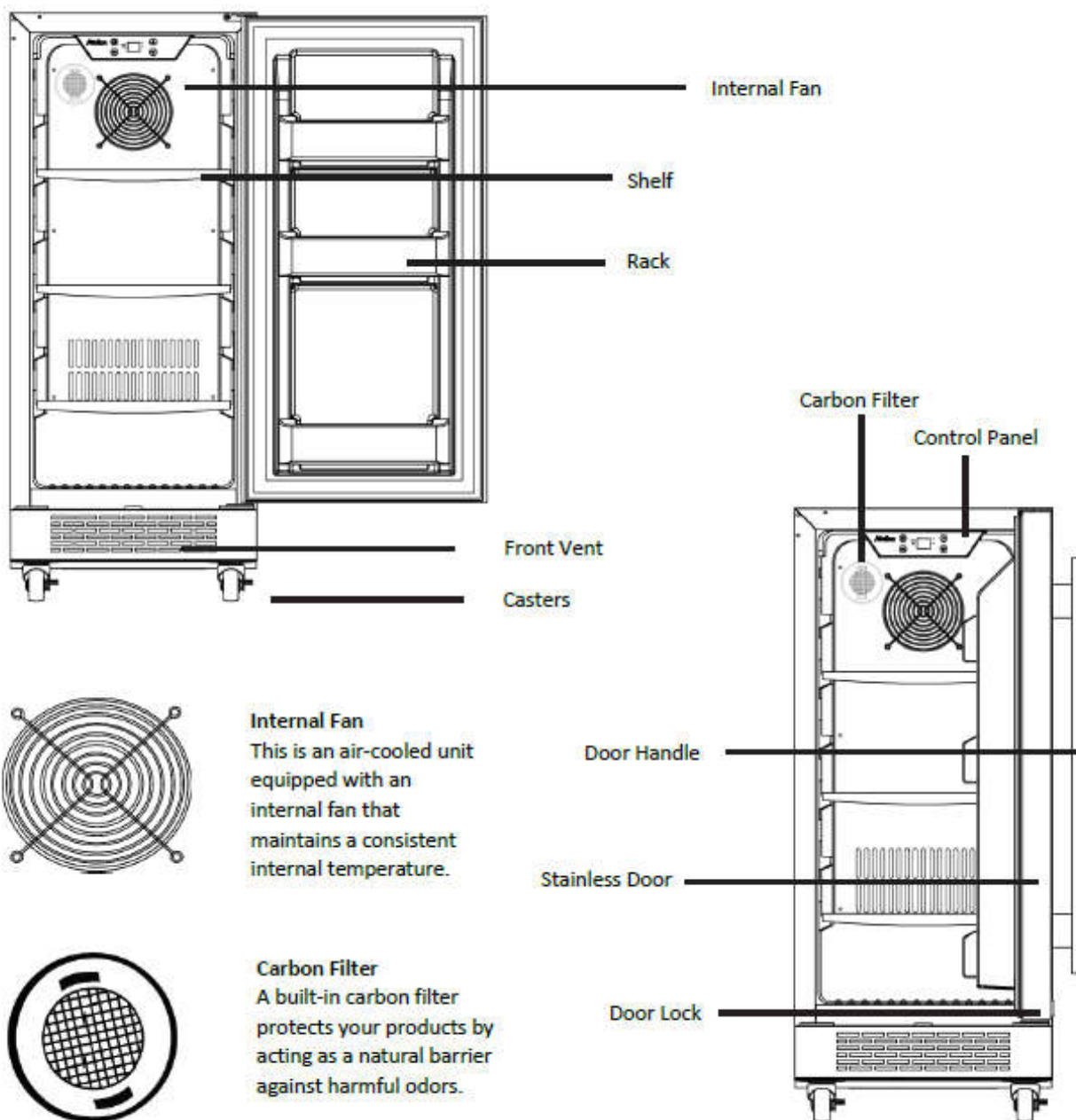

# 2. PARTS IDENTIFICATION

Models: AFR151SS

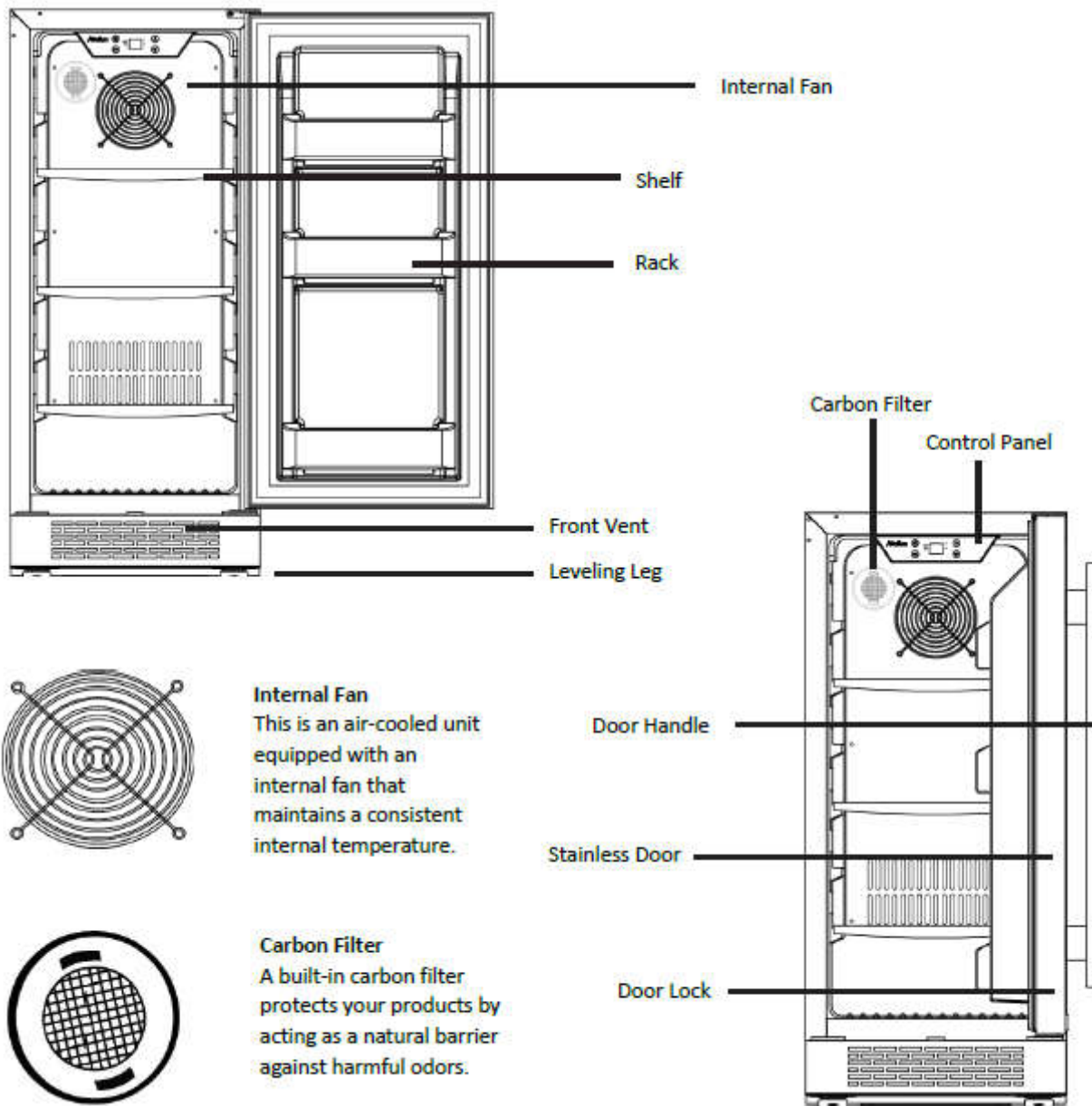

M:

# 2. PARTS IDENTIFICATION

Models: ABR151SG

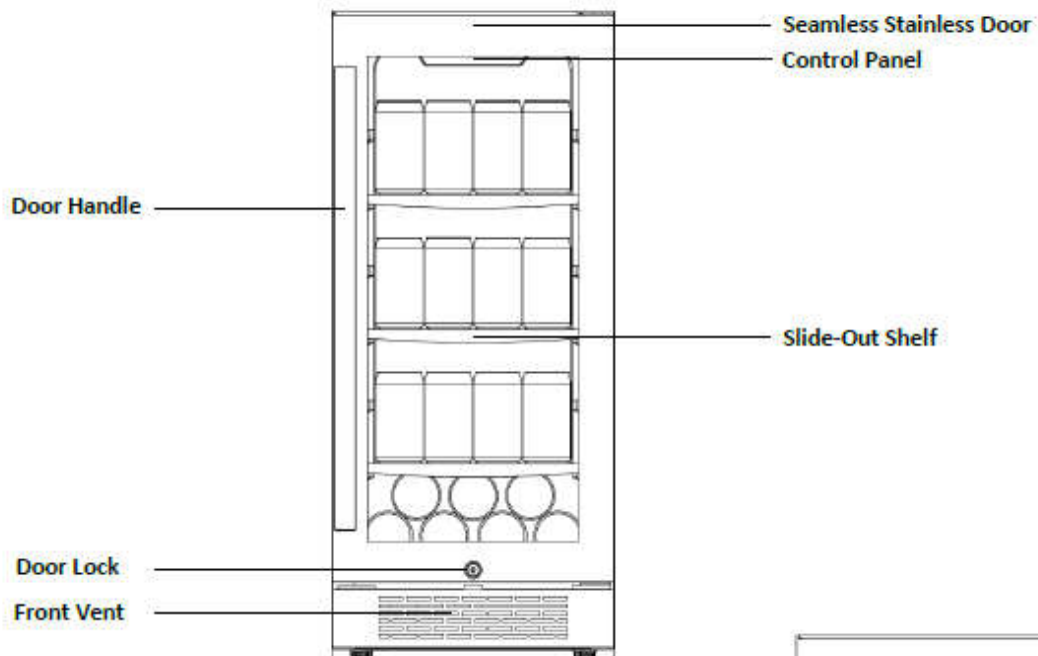

**Carbon Filter**  
A built-in carbon filter protects your beverage by acting as a natural barrier against harmful odors.

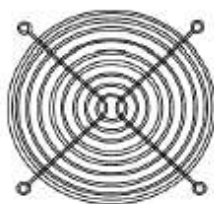

**Internal Fan**  
This is an air-cooled unit equipped with an internal fan that maintains a consistent internal temperature.

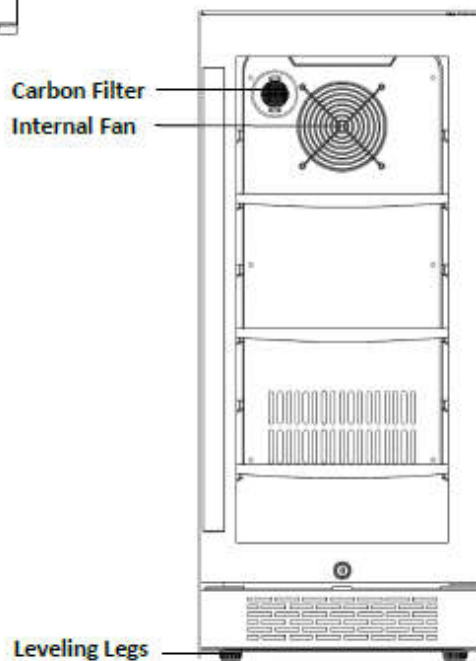

## 2. PARTS IDENTIFICATION

---

Models: AWC151SZ

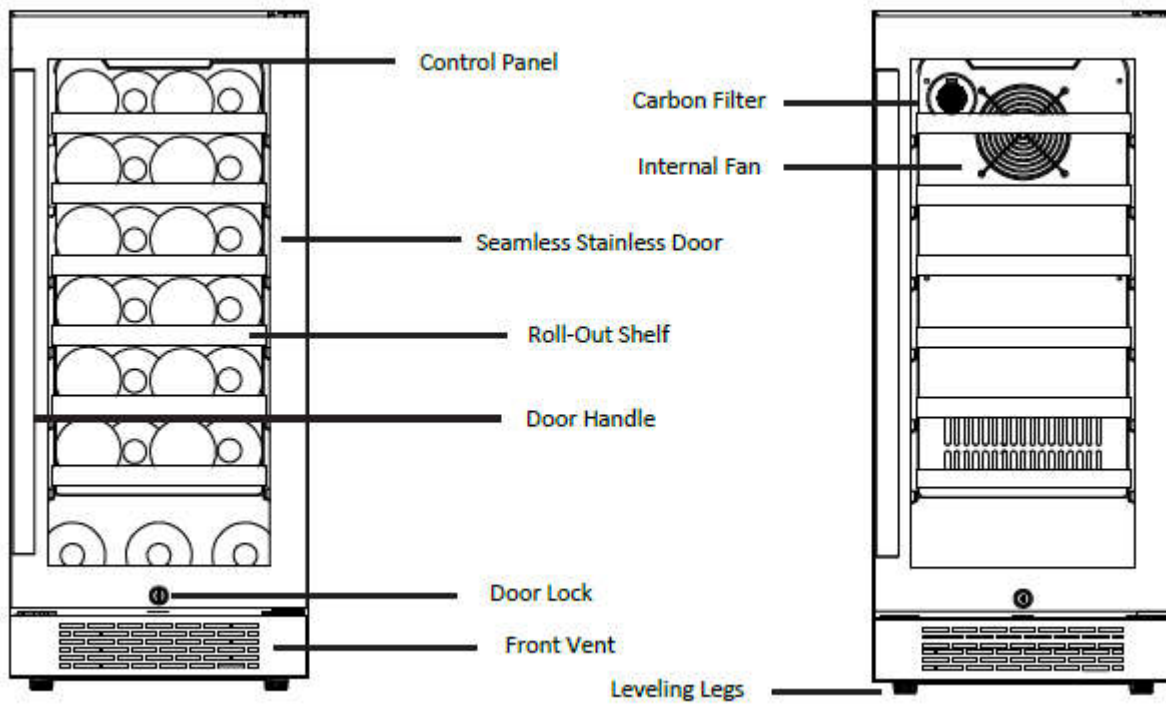

## 2. PARTS IDENTIFICATION

---

Models: ABR241SG

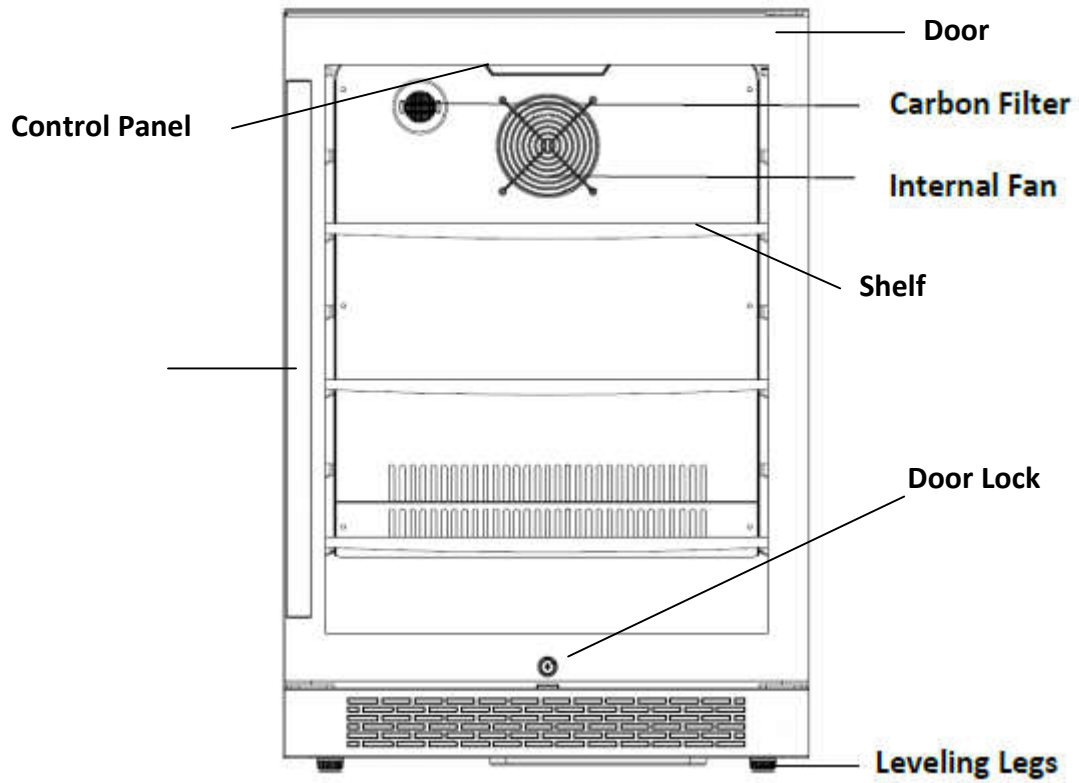

## 2. PARTS IDENTIFICATION

Models: AWC241SZ

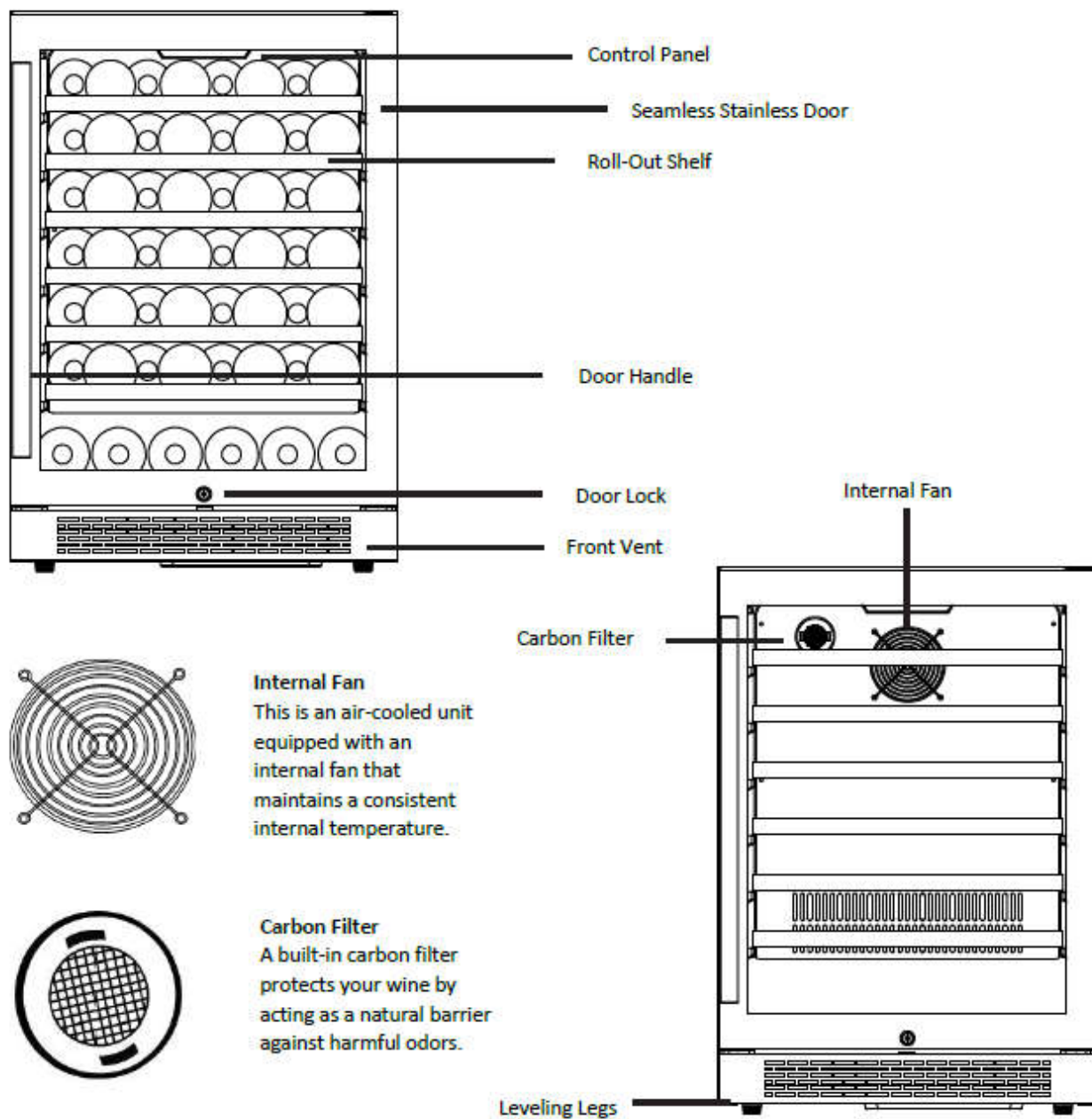



## 2. PARTS IDENTIFICATION

Models: AFR241SS

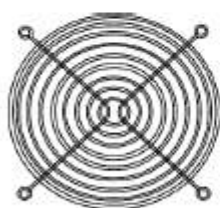
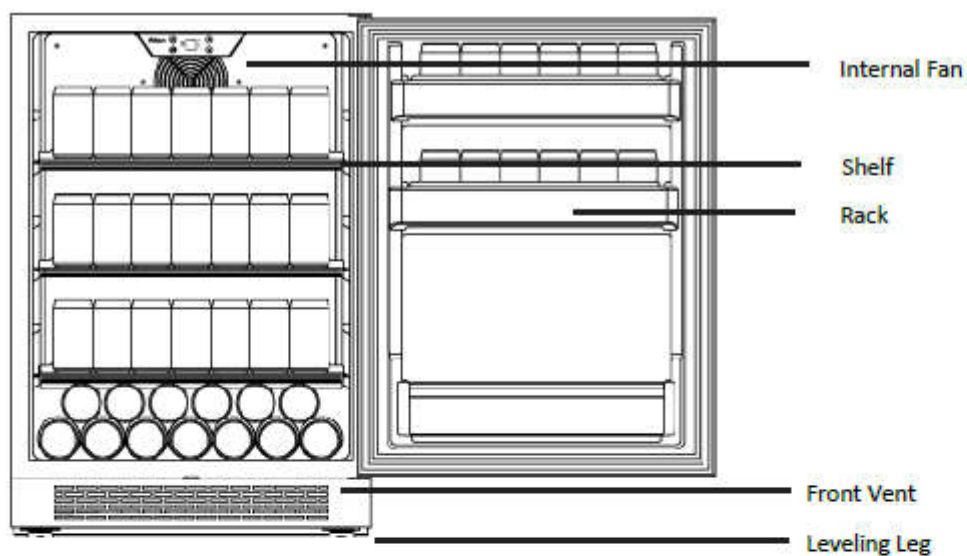

**Internal Fan**  
This is an air-cooled unit equipped with an internal fan that maintains a consistent internal temperature.



**Carbon Filter**  
A built-in carbon filter protects your products by acting as a natural barrier against harmful odors.

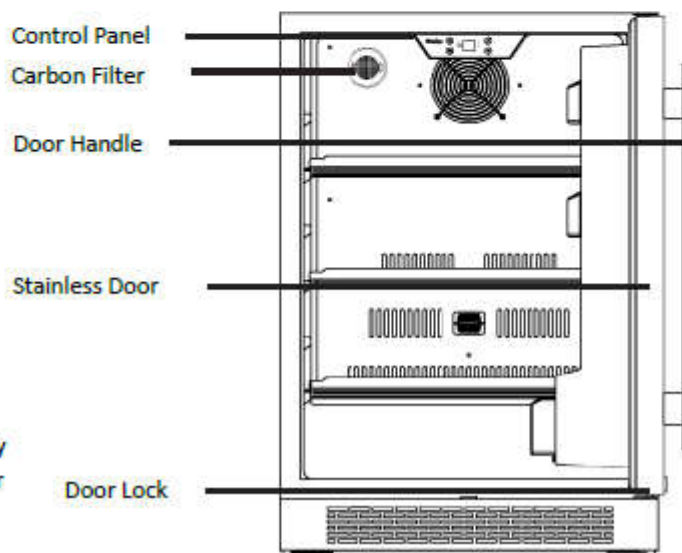

# 2. PARTS IDENTIFICATION

Models: AFR241SSOD

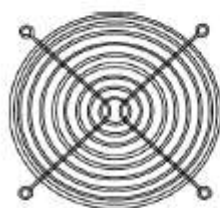
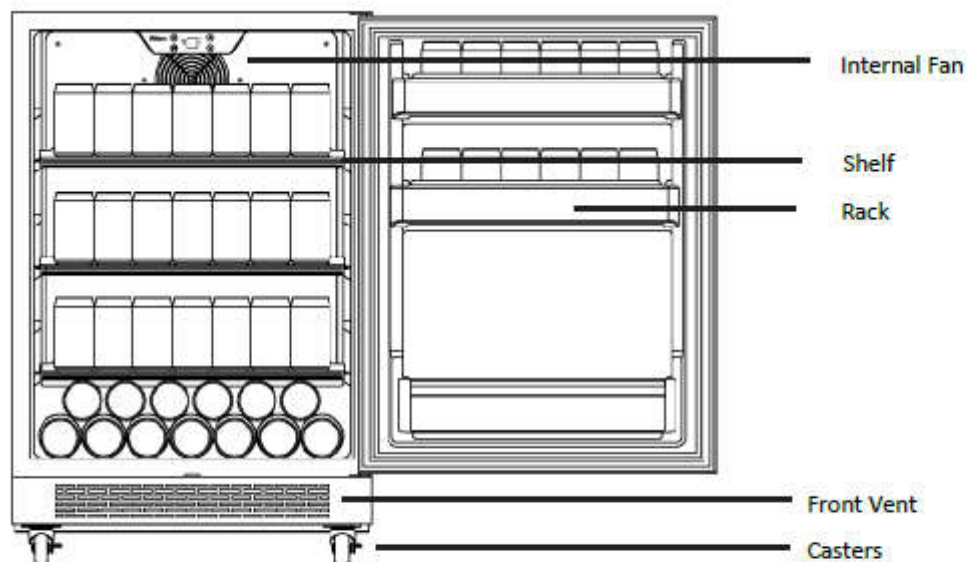

**Internal Fan**  
This is an air-cooled unit equipped with an internal fan that maintains a consistent internal temperature.



**Carbon Filter**  
A built-in carbon filter protects your products by acting as a natural barrier against harmful odors.

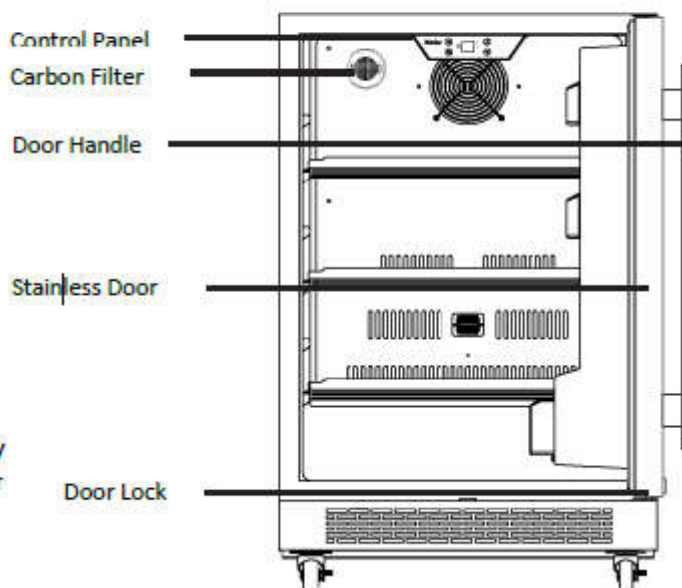

## 2. PARTS IDENTIFICATION

---

Models: AWC241TSZ

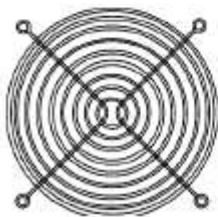
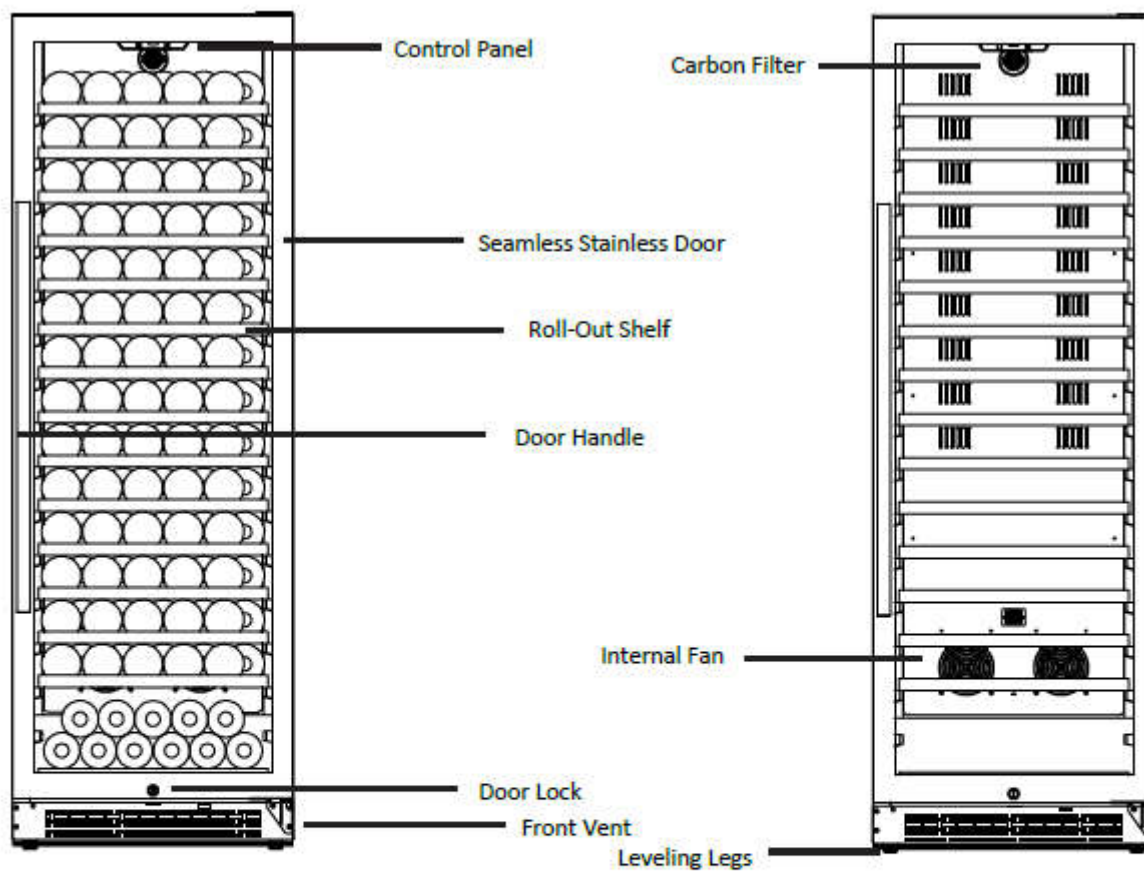

**Internal Fan**  
This is an air-cooled unit equipped with an internal fan that maintains a consistent internal temperature.



**Carbon Filter**  
A built-in carbon filter protects your wine by acting as a natural barrier against harmful odors.

# 2. PARTS IDENTIFICATION

Models: AWC241FD

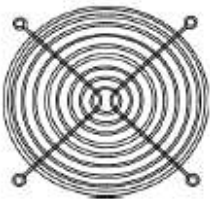
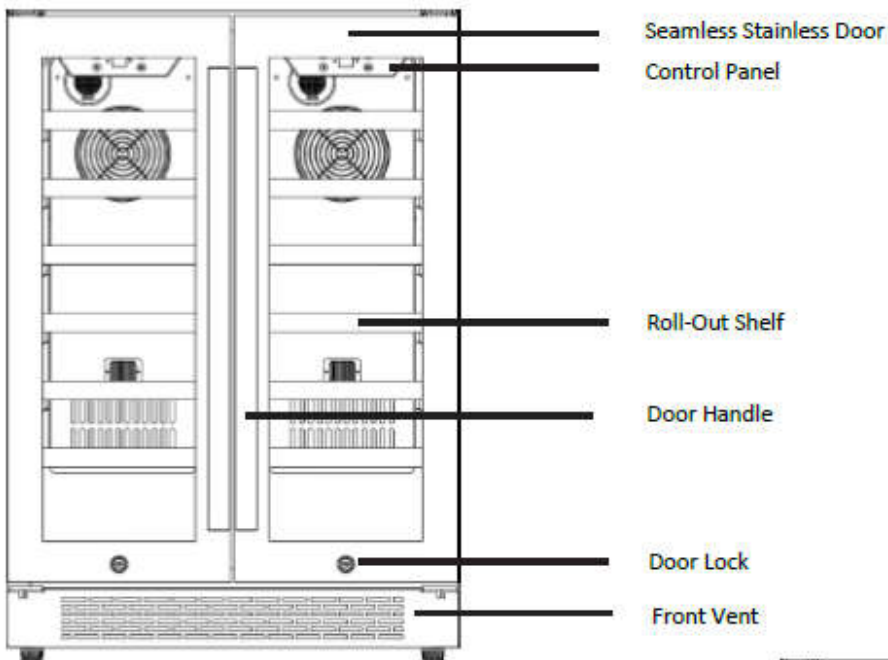

**Internal Fan**  
This is an air-cooled unit equipped with an internal fan that maintains a consistent internal temperature.



**Carbon Filter**  
A built-in carbon filter protects your wine by acting as a natural barrier against harmful odors.

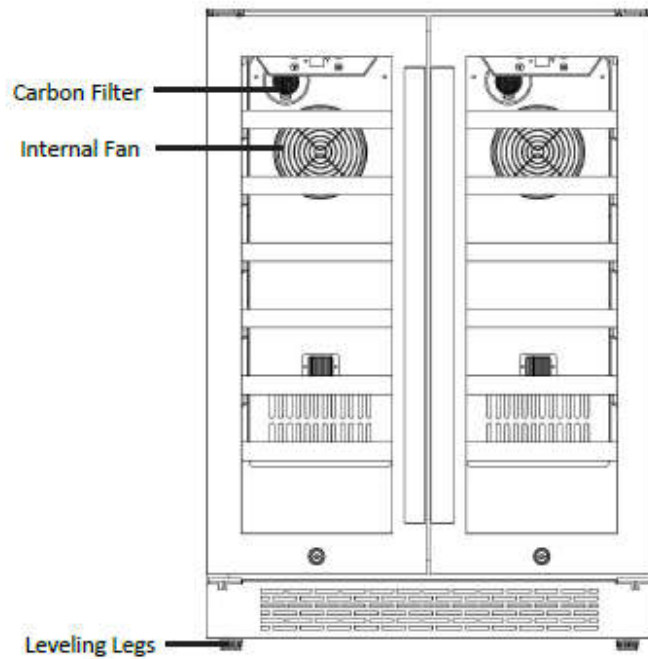

# 3. DISASSEMBLY

## 3-1 DOOR

(Models: AFR151SSOD, AFR151SS, ABR151SG, AWC151SZ, ABR241SG, AWC241SZ, AFR241SS, AFR241SSOD, AWC241FD)

Loosen 2 bolts securing the lower door axis to the lower hinge to remove the door. (Figure 1)

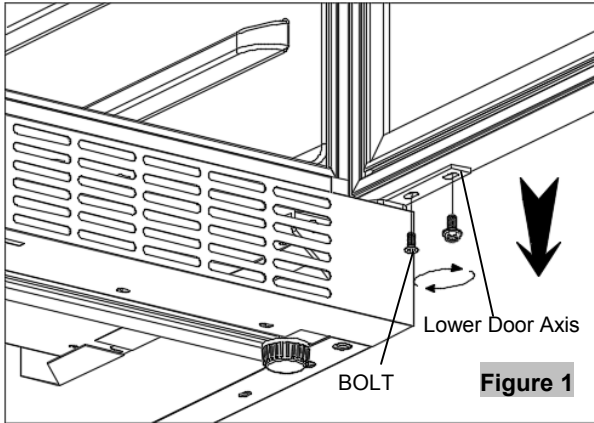

Figure 1

(Models: AWC241TSZ)

Loosen 2 bolts securing the lower door axis to the lower hinge to remove the door. (Figure 2)

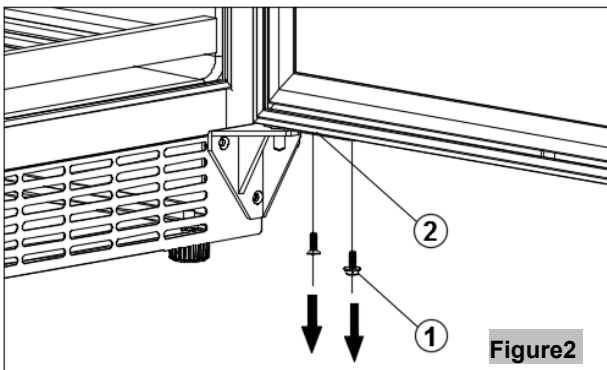

Figure 2

## 3-2 GLASS SHELVES

(Models: AFR151SSOD, AFR151SS, ABR151SG, ABR241SG)

- Open the door completely.
- Lift either the left or right side of the shelf creating a 45° angle from its original position. Make sure not to lift either side of the shelf too hard as it may come in contact with the inner wall mount.
- Pull the shelf outward until it is removed from the inner compartment. You may encounter some resistance from the shelf guard rail. (figure 3)

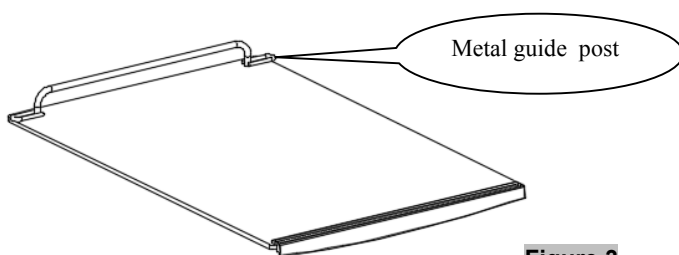

Figure 3

(Model: AFR241SS, AFR241SSOD)

1. Open the door completely.
2. Remove all of the contents loaded on the shelf, if applicable.
3. With the shelf pushed all the way to the rear of the unit, position the cutouts in the left & right sides of the shelves under the plastic posts on each side of the shelf track.
4. Push down on the front of the shelf while lifting up on the rear of the shelf (picture a seesawing motion) until the shelf passes over the plastic posts.
5. Pull the shelf forward until it is completely removed from the inner compartment. (figure 5)

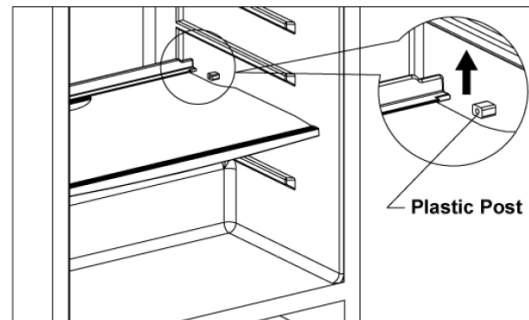

Figure 5

## 3-3 WIRES SHELVES:

(Model: AWC151SZ, AWC241SZ)

- you must pull the shelves approximately 1/3 out of the rail compartment.
- To remove the shelves of the rail, pull each shelf approximately 1/3 out. Use a long flat screwdriver to press down the right plastic notch as shown in Figure 3 and at the same time lift the left plastic notch as shown in Figure 4. Then proceed to pull out the shelf slowly. (figure 4)

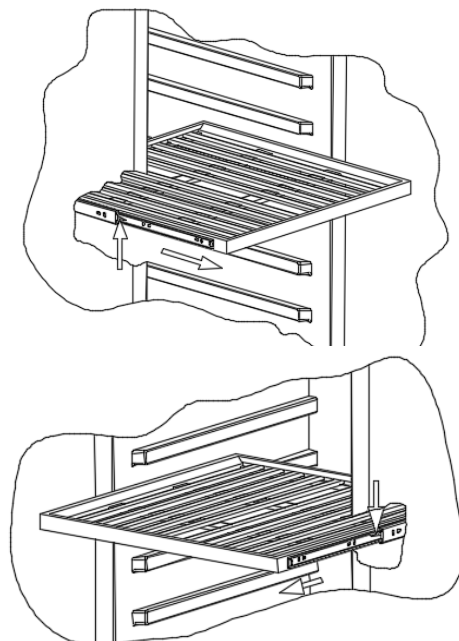

Figure 4



# 3. DISASSEMBLY

(Model: AWC241TSZ)

1. Open the door completely.
2. Remove all of the contents loaded on the shelf, if applicable.
3. Line up the shelf notches with the rail posts as indicated below. This will require you to hold on to both rails as you move the shelf to line up the posts with the notches on both sides of the shelf.
4. Evenly lift the shelf up and then pull the shelf out. (Figure 6)

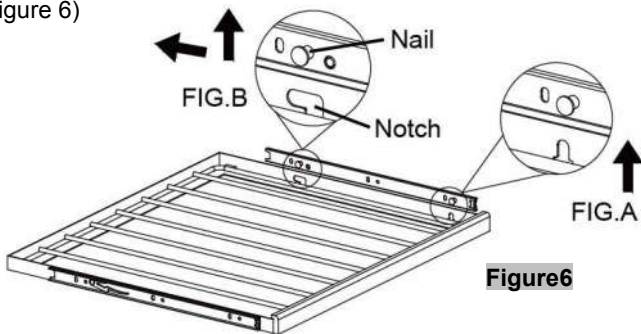

- Open the door completely.
- If necessary, make sure you remove all the contents sitting on the shelf.
- Pull the shelf forward until the notch aligns with the plastic post on each side of the shelf track.
- Lift the shelf until both notches pass through the posts. Continue to pull the shelf forward until it is completely removed from the inner compartment. (Figure 7)

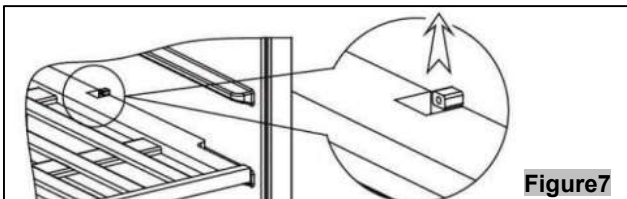

## 3-6 TOP LAMP

(Models: AFR151SSOD, AFR151SS, ABR151SG, AWC151SZ, , ABR241SG, AWC241SZ, AFR241SS, AFR241SSOD, AWC241TSZ, AWC241FD.)

1. Loosen four screws. (figure 8)



Figure 8

screw

2. Unplug the led light connector. (figure 9)

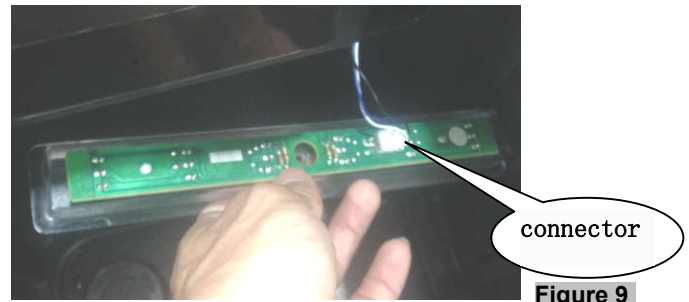

Figure 9

3. Loosen four screws. (figure 10)

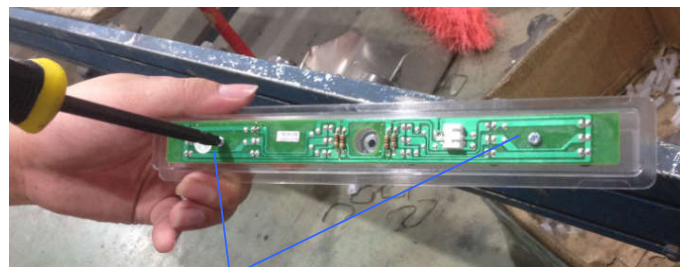

Figure 10

Screw

4. Pull out the LED light. The LED light is like below. (figure 11)



Figure 11

## 3-7 BROADSIDE LAMP

(Models: AFR151SSOD, AFR151SS, ABR151SG, AWC151SZ, , ABR241SG, AWC241SZ, AFR241SS, AFR241SSOD, AWC241TSZ, AWC241FD.)

1. Pull the lamp cover.
2. Separate the claw attached to the LED light. Separate the lead wire housing. (figure 12)

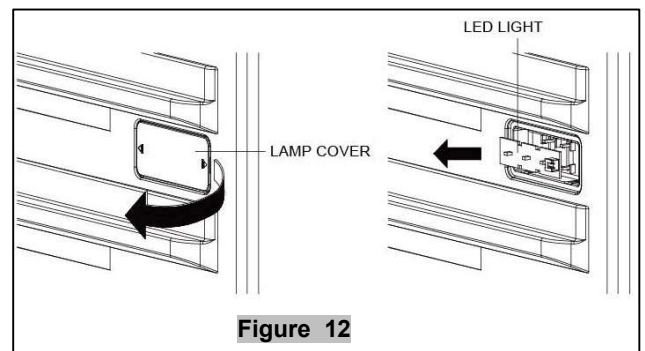

Figure 12

3. The LED light is pictured below. (figure 13)



Figure 13

# 3. DISASSEMBLY

## 3-8 DISPLAY BOARD & CONTROL BOARD

(Models: AFR151SSOD, AFR151SS, ABR151SG, AWC151SZ, ABR241SG, AWC241SZ, AFR241SS, AFR241SSOD, AWC241TSZ, AWC241FD)

1. Loosen four screws.
2. Pull out the electrical box.
3. Unplug all cable connectors. (figure 14)

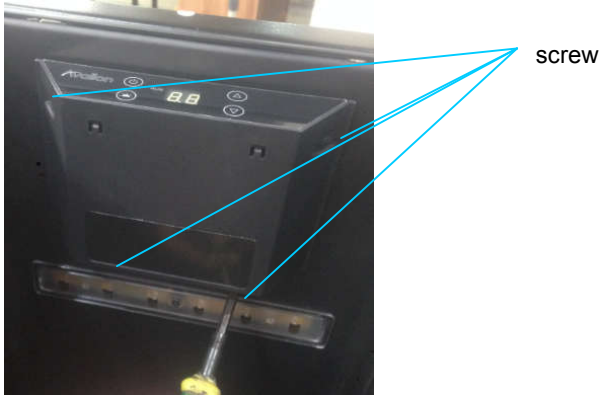

Figure 14



4. Loosen four screws. (figure 15)



Figure 15

5. The control board is pictured below. (figure 16)



Figure 16

6. Remove the display cover. Pull out the display board support and find out the display board inside it. (figure 17)



Figure 17

7. The display board is like below. (figure 18)

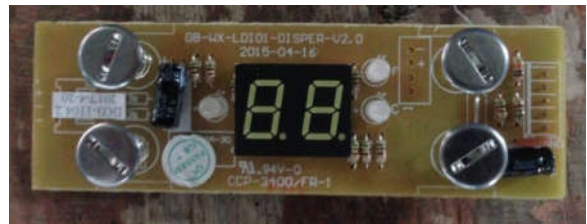

Figure 18

## 3-9 POWER BOARD & TRANSFORMER

(Models: ABR241SG, AWC241SZ, AFR241SS, AFR241SSOD, AWC241TSZ, AWC241FD)

1. Loosen three screws. (figure 19)



Figure 19

2. The power board & transformer are like below. (figure 20)

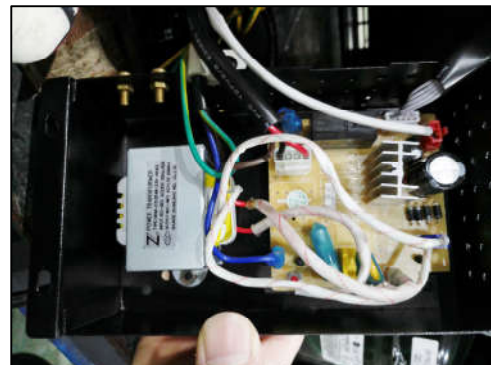

Figure 20

# 3. DISASSEMBLY

(Models: AFR151SSOD, AFR151SS, ABR151SG, AWC151SZ)

1. Loosen three screws. (figure 21)



Figure 21

2. The power board & transformer are like below. (figure 22)

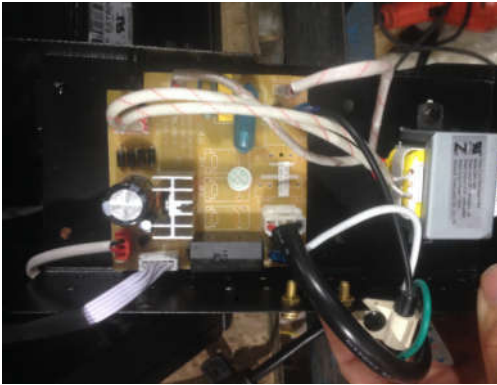

Figure 22

## 3-10 SENSOR & FAN

(Models: AFR151SSOD, AFR151SS,)

1. Remove the screws on both sides of air duct board.. Pull out the air duct board cover. (figure 23)

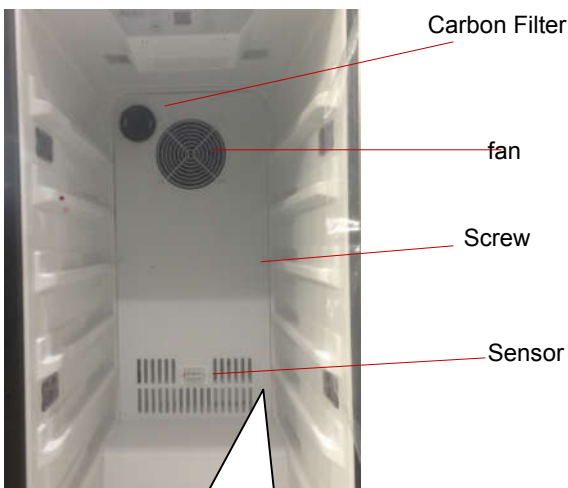

Figure 23

Remove the cover screws



(Models: ,ABR151SG, AWC151SZ)

- 1.1 Loosen six screws. Pull out the rear air duct cover. (figure 24)

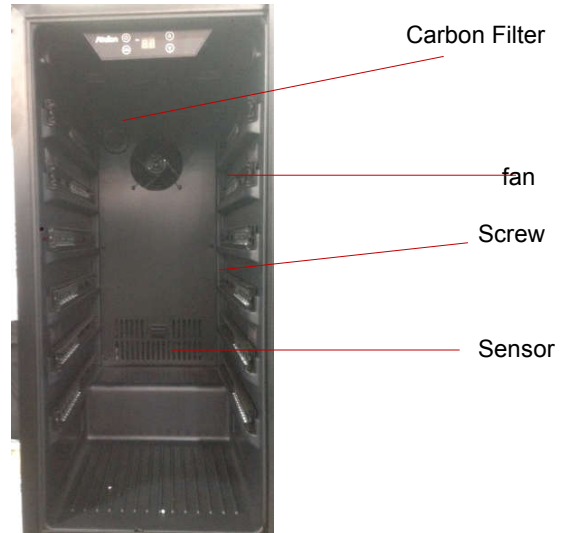

Figure 24

2. Loosen 1 screw. You can replace the sensor & fan. (figure 25)

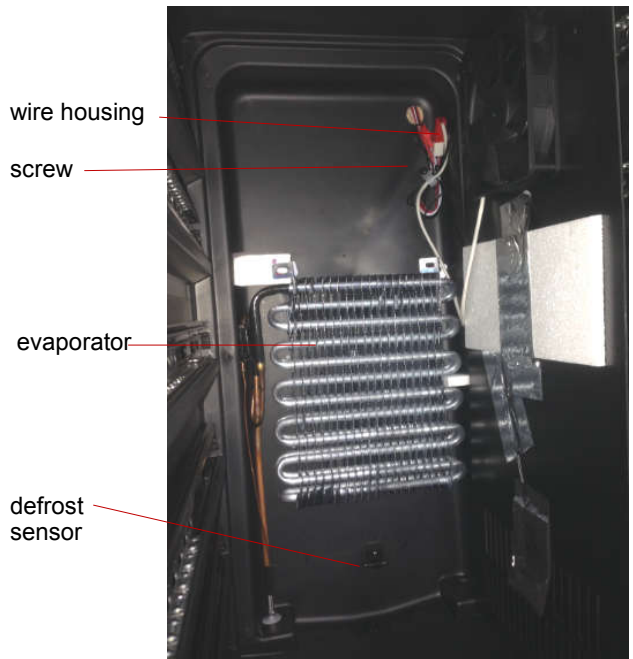

Figure 25



# 3. DISASSEMBLY

(Models: ABR241SG, AWC241SZ)

1. Loosen six screws. Pull out the rear air duct cover. (figure 26)

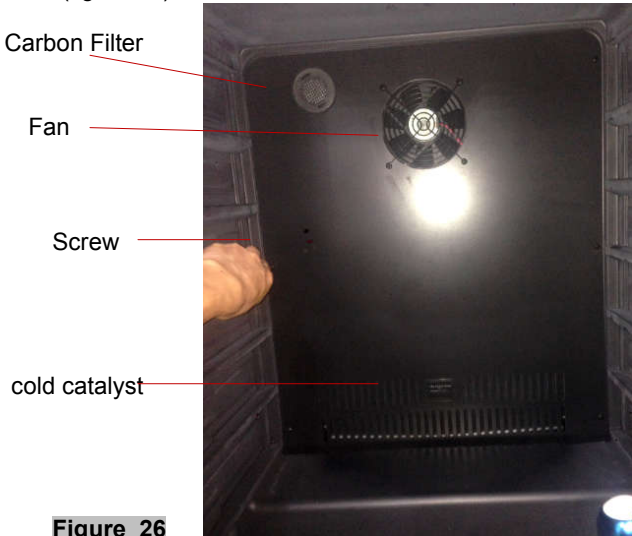

Figure 26

2. Loosen 1 screw. You can replace the sensor & fan. (figure 27)

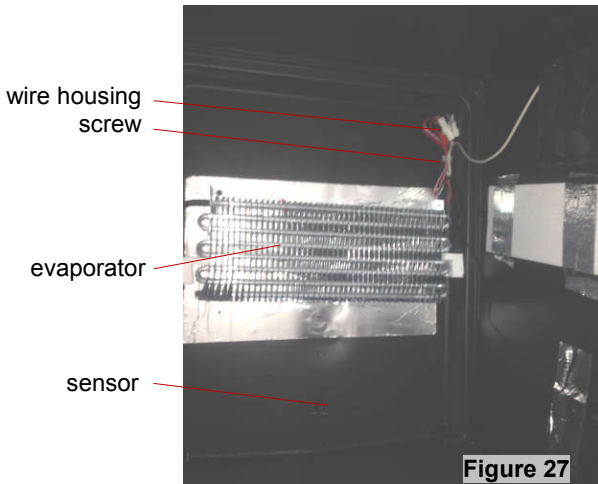

Figure 27

(Models: AFR241SS, AFR241SSOD)

1. Loosen screws. Pull out the rear air duct cover. (figure 28)

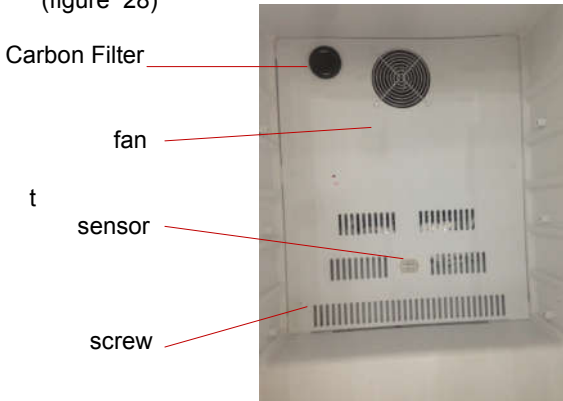

Figure 28

2. Loosen 1 screw to replace the sensor & fan. (figure 29)

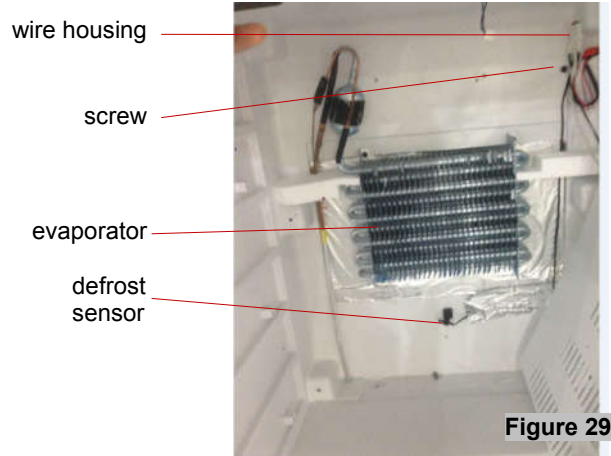

Figure 29

(Models: AWC241TSZ)

1. Loosen screws. Pull out the rear air duct cover. (figure 30)

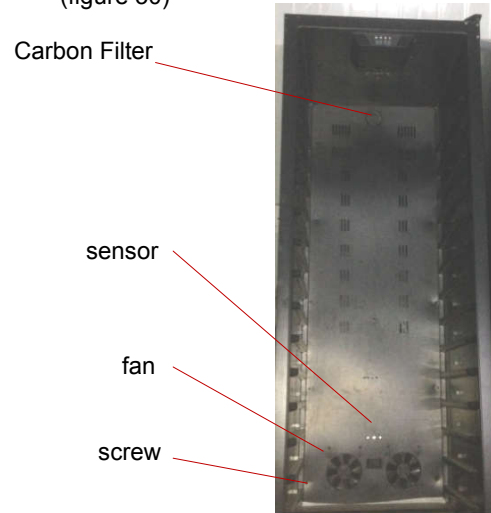

Figure 30

2. Loosen 1 screw to replace the sensor & fan.
3. (figure 31)

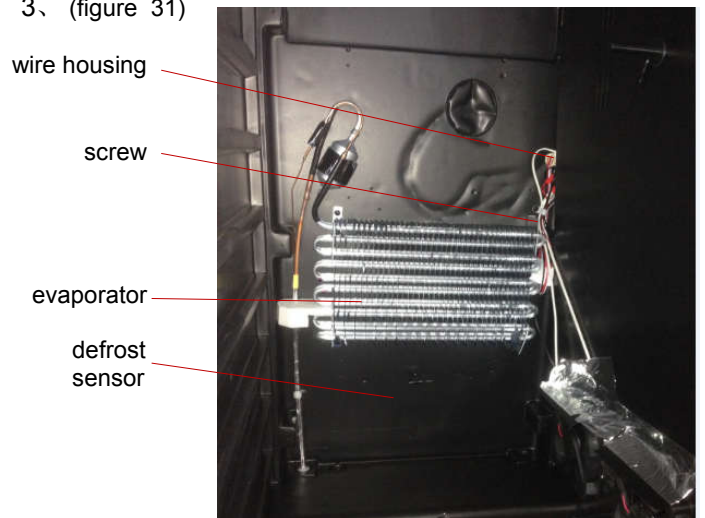
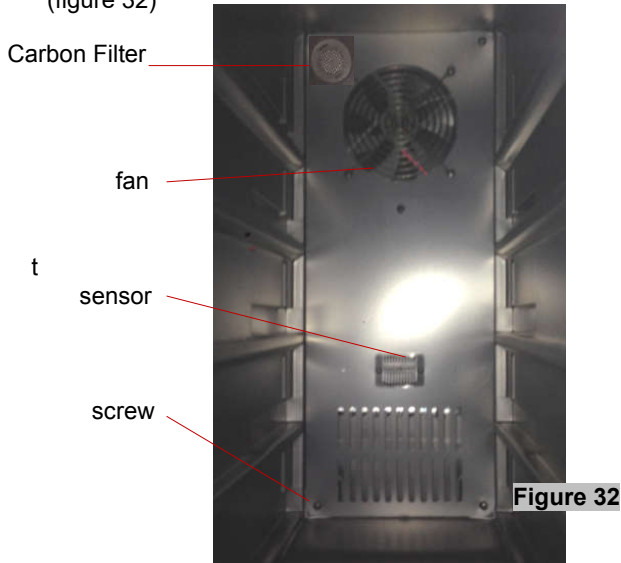

Figure 31

# 3. DISASSEMBLY

(Models: AWC241FD)

- Loosen screws. Pull out the rear air duct cover. (figure 32)



- Loosen screw. You can replace the sensor & fan. (figure 33)

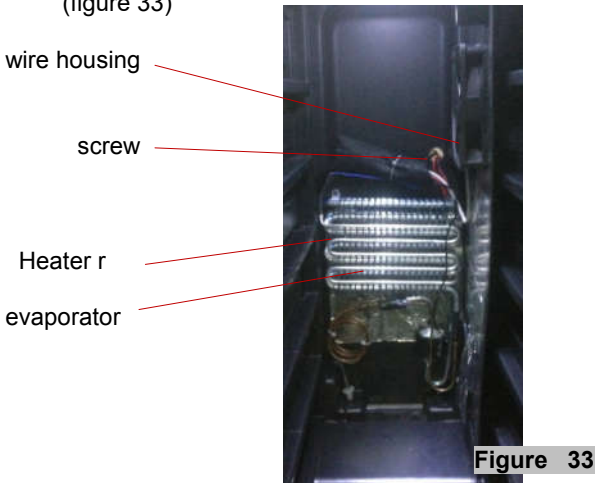

## 3-11 COMPRESSOR PTC STARTER & OVERLOAD PROTECTOR

(Models: AFR151SSOD, AFR151SS, ABR151SG, AWC151SZ, ABR241SG, AWC241SZ, AFR241SS, AFR241SSOD)

- Open the box near compressor, the starter and overload protector are located inside. (figure 34)



- Dismantle the compressor PTC starter and overload protector. (figure 35)

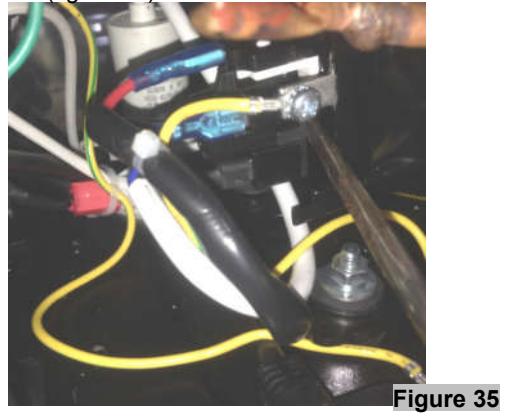

- The compressor PTC starter and overload protector is like below. (figure 36)

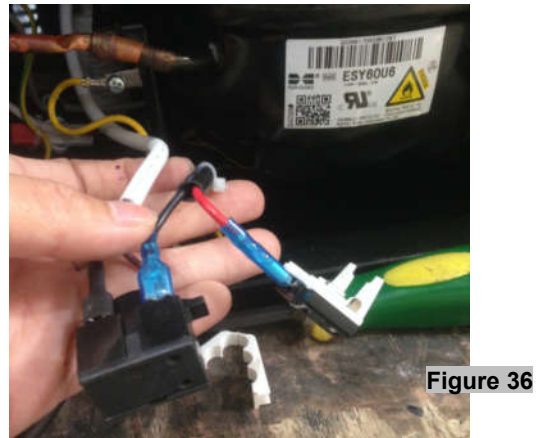

(Models: AWC241FD)

- Open the box near compressor, The starter and overload protector are located inside. (figure 37)



# 3. DISASSEMBLY

- 2. Dismantle the compressor PTC starter and overload protector. (figure 38)

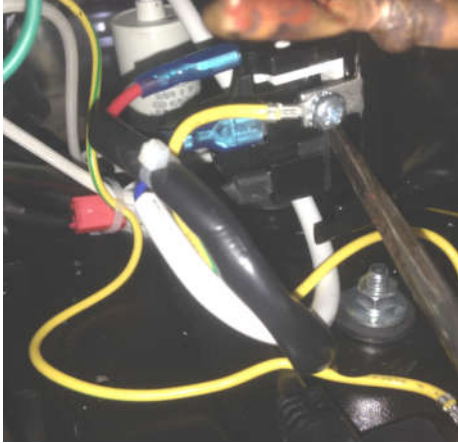

Figure 38

- 3. The compressor PTC starter and overload protector is pictured below. (figure 39)

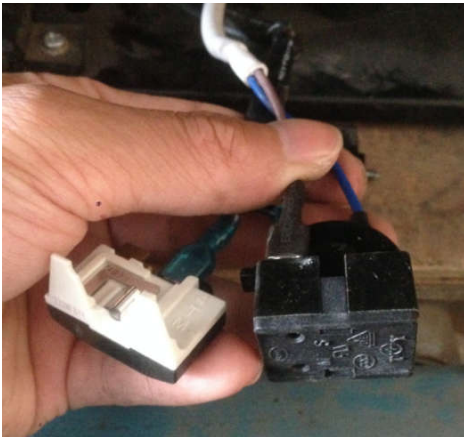

Figure 39

(Models: AWC241TSZ)

- 1. Open the box near compressor. The starter and overload protector are located inside. (figure 40)



Figure 40

- 2. Remove the compressor junction box. (figure 41)



Figure 41

- 3. The compressor PTC starter and overload protector is pictured below. (figure 42)

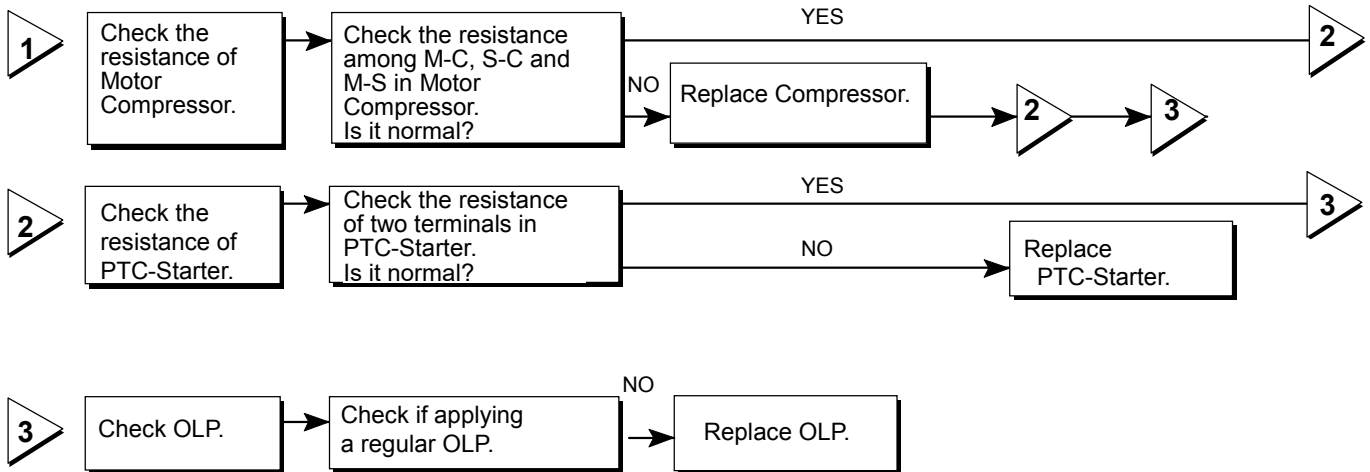

Figure 42

# 4. TROUBLESHOOTING

---

## 4-1 COMPRESSOR COMPONENTS



# 4. TROUBLESHOOTING

## 4-2 ANOTHER ELECTRIC COMPONENTS

### ▼ Cooling is impossible

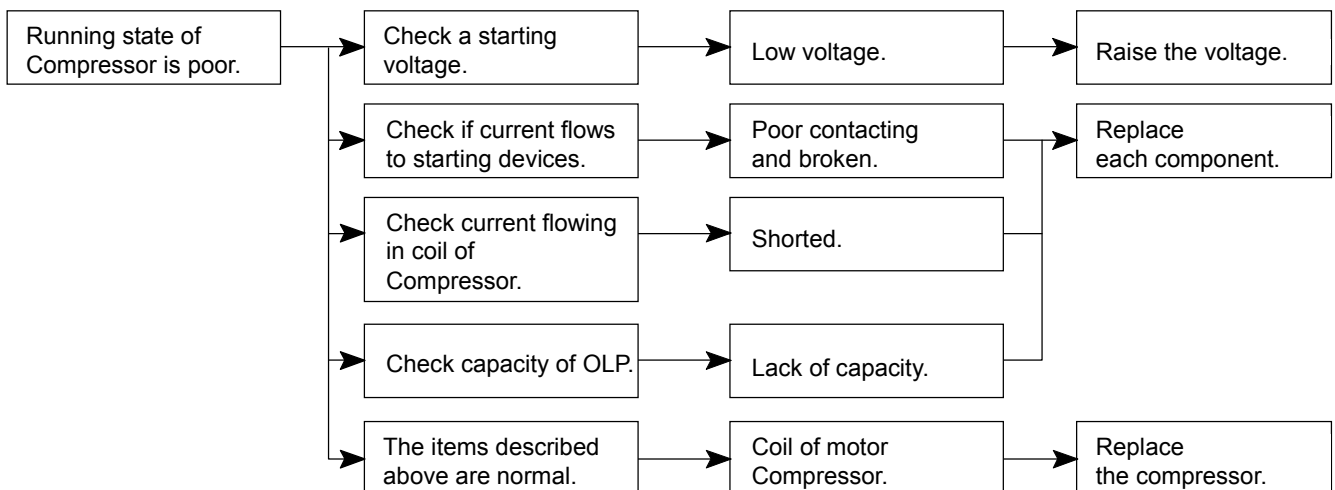
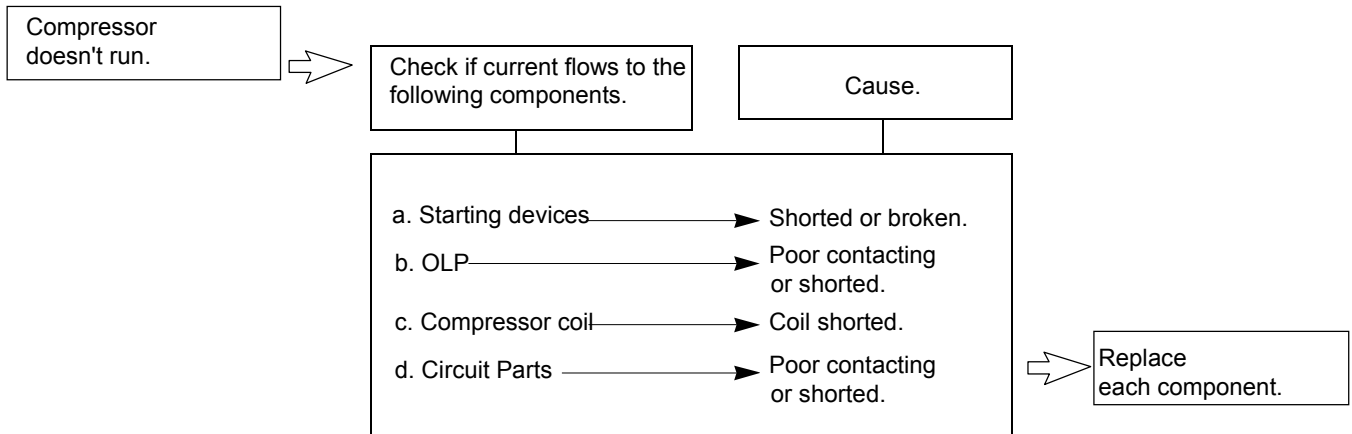

### ▼ Cooling ability is poor

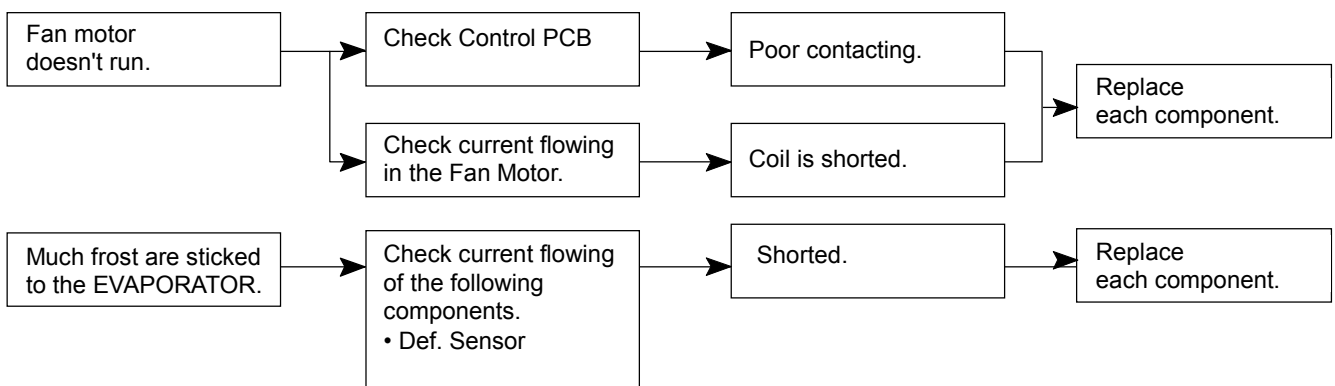

# 4. TROUBLESHOOTING

## 4-3 SERVICE DIAGNOSIS CHART

Problem	Possible Cause
Appliance does not operate.	Not plugged in. The appliance is turned off. The circuit breaker tripped or a blown fuse.
Appliance is not cold enough.	Check the temperature control setting. External environment may require a higher setting. The door is opened too often. The door is not closed completely. The door gasket does not seal properly.
Turns on and off frequently.	The room temperature is hotter than normal. A large amount of contents has been added to the wine chiller. The door is opened too often. The door is not closed completely. The temperature control is not set correctly. The door gasket does not seal properly.
The light does not work.	Not plugged in. The circuit breaker tripped or a blown fuse. The bulb has burned out. The light button is "OFF". Energy conservation button is on.
Vibrations.	Check to assure that the appliance is level.
The appliance seems to make too much noise.	The rattling noise may come from the flow of the refrigerant, which is normal. As each cycle ends, you may hear gurgling sounds caused by the flow of refrigerant in your refrigeration appliance. Contraction and expansion of the inside walls may cause popping and crackling noises. The appliance is not level.
The door will not close properly.	The appliance is not level. The door was reversed and not properly installed. The gasket is dirty. The shelves are out of position.
Display error code "E1"	The air sensor has an open circuit. Connection to main control PCB is with white color wires. Check the circuit, if it is normal, the sensor may need to be replaced.
Display error code "E2"	The air sensor has a short circuit. Connection to main control PCB is with white color wires. Check the circuit, if it is normal, the sensor may need to be replaced.
Display error code "E3".	The defrost sensor has an open circuit. Connection to main control PCB is with red color wires. Check the circuit, if it is normal, the sensor may need to be replaced.
Display error code "E4".	The defrost sensor has a short circuit. Connection to main control PCB is with red color wires. Check the circuit, if it is normal, the sensor may need to be replaced.



# 4. TROUBLESHOOTING

## 4-4 REFRIGERATING CYCLE

### ▼ Troubleshooting Chart

	CAUSE	STATE OF UNIT	STATE OF EVAPORATOR	TEMPERATURE OF COMPRESSOR	COMMENTS
LEAKAGE	PARTIAL LEAKAGE	Appliance does not get cold enough	Low flowing sound of Refrigerant is heard and frost forms	A little high - more than ambient room temperature.	<ul style="list-style-type: none"> <li>• A little refrigerant discharges</li> <li>• Normal cooling is possible when charging refrigerant of regular amount stated on specification plate / rating label.</li> </ul>
	WHOLE LEAKAGE	Appliance does not get cold at all	Flowing sound of Refrigerant is not heard and frost isn't formed.	A little high - more than ambient room temperature.	<ul style="list-style-type: none"> <li>• A little refrigerant discharges</li> <li>• Normal cooling is possible when charging refrigerant of regular amount stated on specification plate / rating label.</li> </ul>
CLOG IN CAPILLARY	PARTIAL RESTRICTION	Appliance does not get cold enough	Flowing sound of Refrigerant is heard and frost forms	A little high - more than ambient room temperature.	<ul style="list-style-type: none"> <li>• No discharging of refrigerant</li> <li>• The capillary tube is faulty.</li> <li>• The filter dryer is faulty.</li> <li>• The condenser is faulty.</li> <li>• The evaporator is faulty.</li> </ul>
	WHOLE RESTRICTION	Appliance does not get cold	Flowing sound of Refrigerant is not heard and frost isn't formed.	A little high - more than ambient room temperature.	<ul style="list-style-type: none"> <li>• No discharging of refrigerant</li> </ul>

Observe refrigerant discharging point. Oil discharge/stain is often best indicator. Use bubbles to locate hole in line, evaporator or condenser.

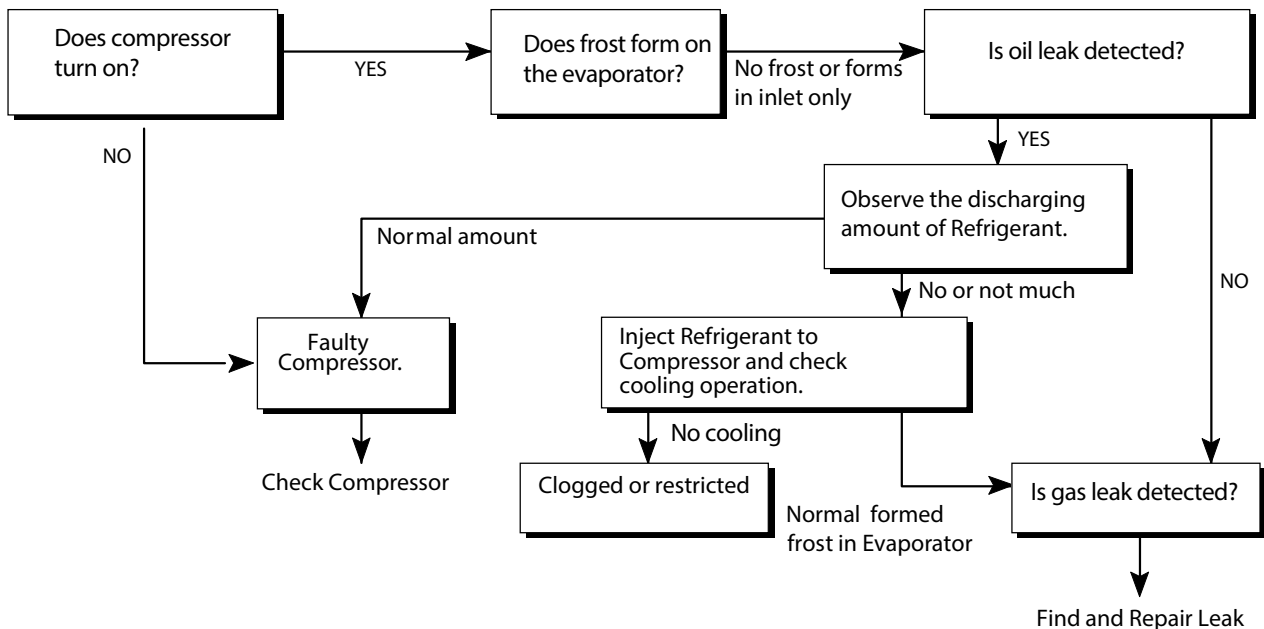

# 5. DESCRIPTION OF PCB

(Models: AFR151SSOD / AFR151SS / ABR151SG / AWC151SZ / ABR241SG AWC241SZ AFR241SS AFR241SSOD AWC241TSZ)

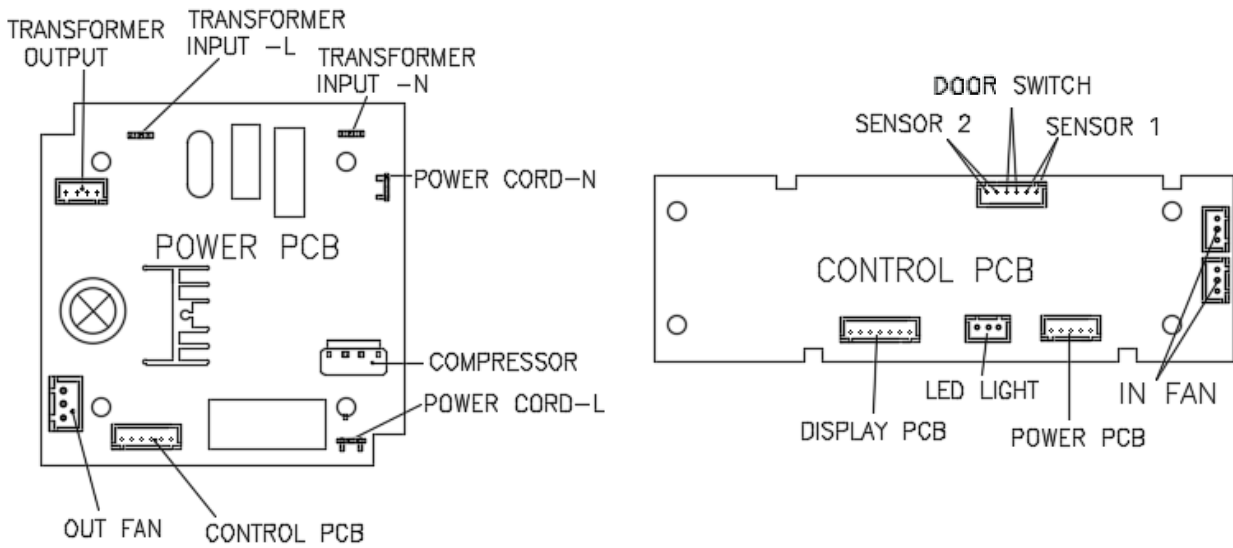

(Models: AWC241FD)

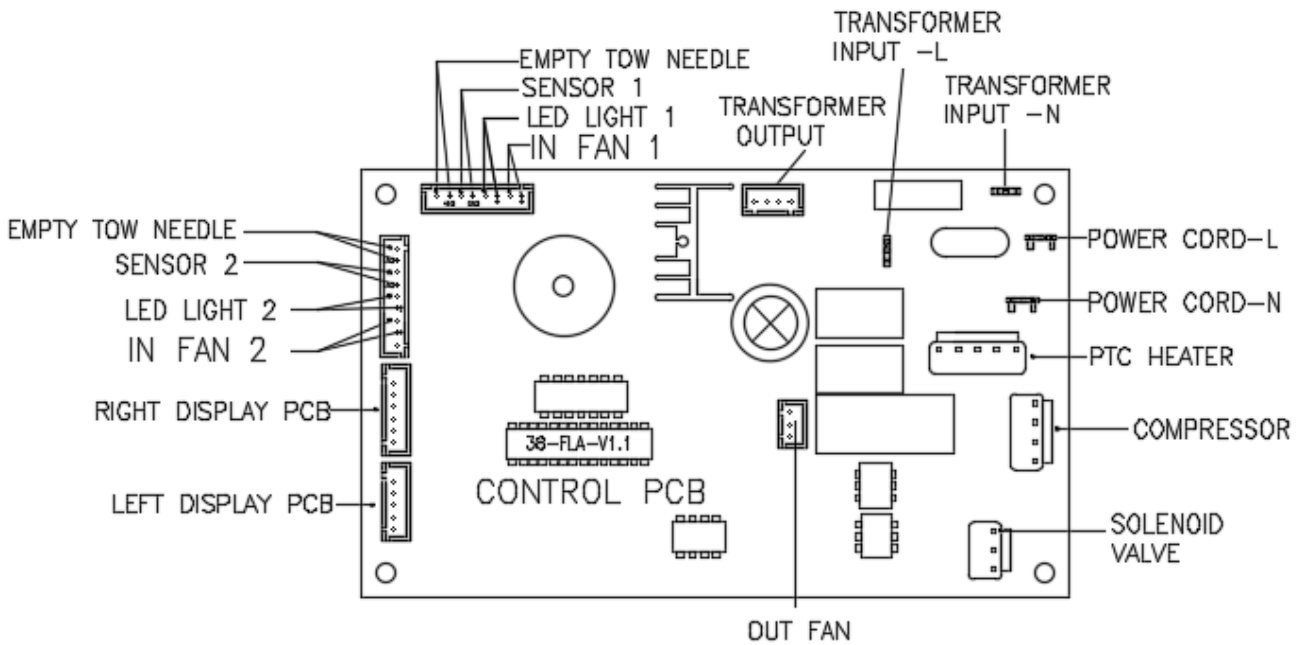



<b>DATE</b>	<b>REVISION NOTES:</b>
9/22/2017	Initial Document
10/16/2017	Minor text edits
10/27/2017	Minor text edits
12/19/2017	Formatting edits