

# SERVICE MANUAL

## Dual Zone Cooler

MODEL:

AWC151DZ, AWC241DZ, AWC241TDZ

**CAUTION: READ ALL SAFETY PRECAUTIONS IN THIS  
MANUAL BEFORE SERVICING THE UNIT**

# CONTENTS

---

SAFETY PRECAUTIONS .....	2
PARTS IDENTIFICATION .....	3-4
DISASSEMBLY .....	5-12
DOOR .....	5
WOODEN SHELVES.....	5
LAMP .....	6
COLD CATALYST SYSTEM.....	7-9
DISPLAY BOARD & CONTROL BOARD.....	7-9
POWER BOARD & TRANSFORMER.....	9
SENSOR & FAN.....	10-11
COMPRESSOR PTC STARTER & OVERLOAD PROTECTOR.....	11-12
TROUBLESHOOTING.....	12-15
COMPRESSOR COMPONENTS .....	12
ANOTHER ELECTRIC COMPONENT .....	13
SERVICE DIAGNOSIS CHART.....	14
REFRIGERATING CYCLE .....	15
DESCRIPTION OF PCB .....	16

# SAFETY PRECAUTIONS

---

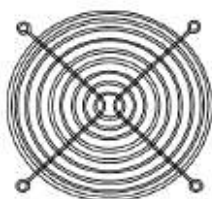
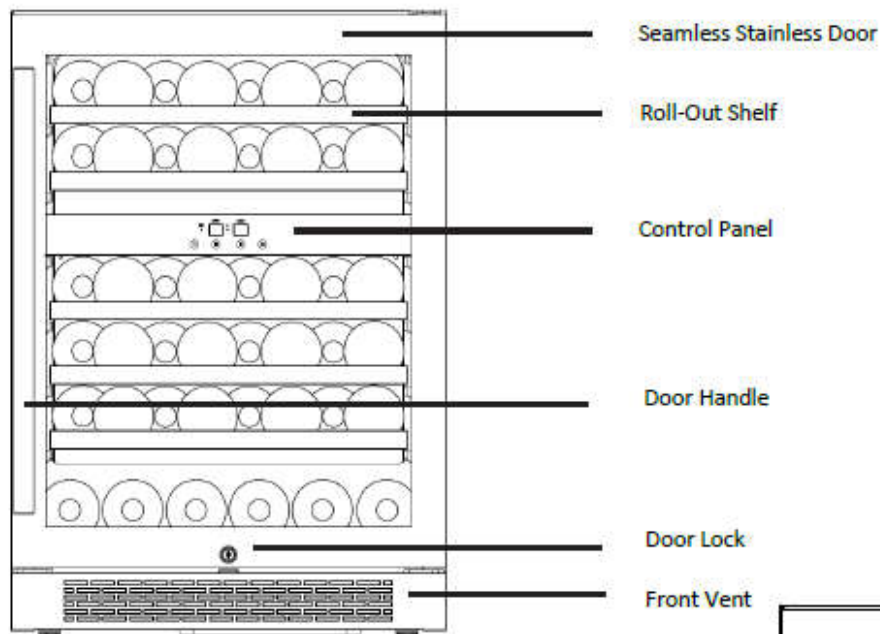
**WARNING: This manual and the information contained herein is intended for use by certified technicians. The manufacturer or seller is not responsible for the interpretation or misuse of the information provided, nor does it assume any liability in connection with its use.**

The safeguards and warnings indicated in this manual do not cover all possible conditions which may occur. Common sense, caution, and care must be exercised.

- To prevent electric shock, always unplug an appliance from the power supply before attempting any service.
- Disconnect the power cord by grasping the plug, not the cord.
- Do not bypass, cut, or remove the grounding plug.
- Prevent water from spilling onto electric elements or the machine parts.
- Always refer to the rating label on the appliance for rated current and voltage.
- Always check line voltage and amperage.
- Always use exact replacement parts.
- Any attempt to repair a major appliance may result in personal injury and property damage.

## 2. PARTS IDENTIFICATION

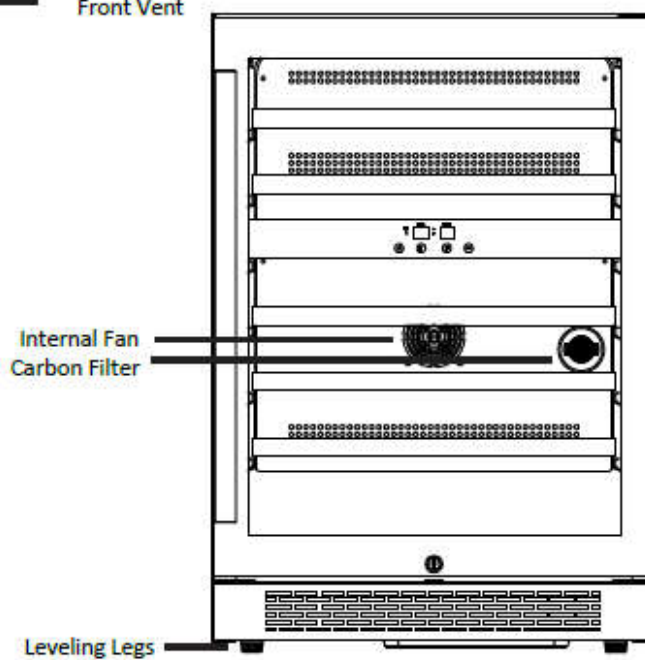
Models: AWC241DZ



**Internal Fan**  
This is an air-cooled unit equipped with an internal fan that maintains a consistent internal temperature.



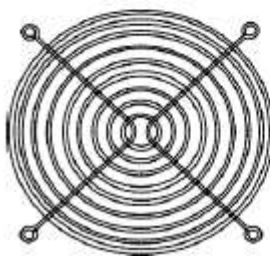
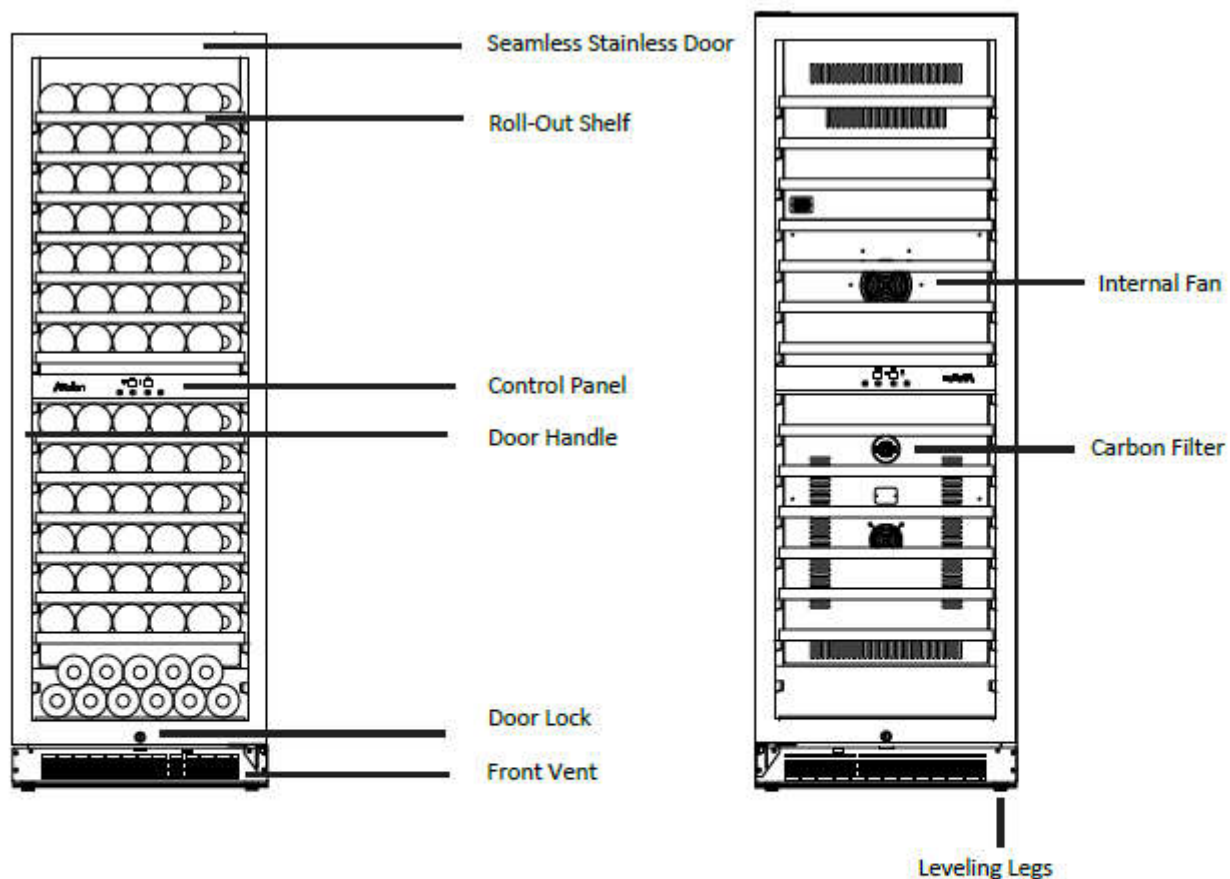
**Carbon Filter**  
A built-in carbon filter protects your wine by acting as a natural barrier against harmful odors.



## 2. PARTS IDENTIFICATION

---

Models: AWC241TDZ



**Internal Fan**  
This is an air-cooled unit equipped with an internal fan that maintains a consistent internal temperature.



**Carbon Filter**  
A built-in carbon filter protects your wine by acting as a natural barrier against harmful odors.

# 3. DISASSEMBLY

## 3-1 DOOR

(Models: AWC151DZ, AWC241DZ)

Loosen 2 bolts securing the lower door axis to the lower hinge to remove the door. (Figure 1)

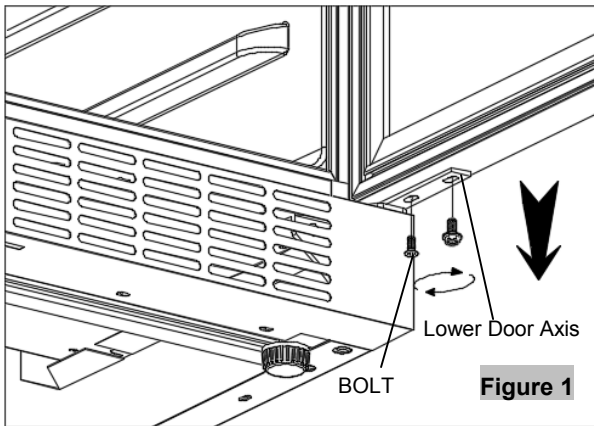


Figure 1

(Models: AWC241TDZ)

Loosen 2 bolts securing the lower door axis to the lower hinge to remove the door. (Figure 2)

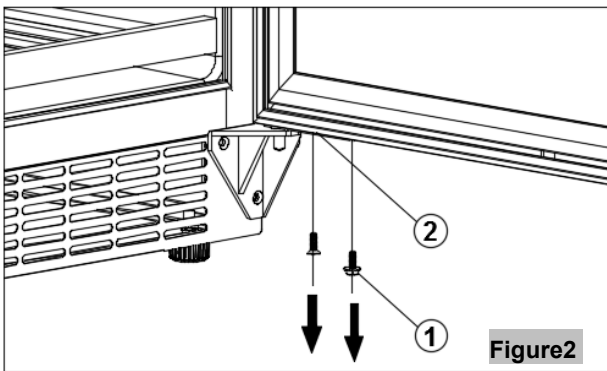


Figure 2

## 3-2 WOODEN SHELVES:

(Model: AWC151DZ, AWC241DZ)

- you must pull the shelves approximately 1/3 out of the rail compartment.
- To remove the shelves out of the rail, pull each shelf approximately 1/3 out. Use a long flat screwdriver to press down the right plastic notch as shown in Figure 3 and at the same time lift the left plastic notch as shown in Figure 3. Then proceed to pull out the shelf slowly.

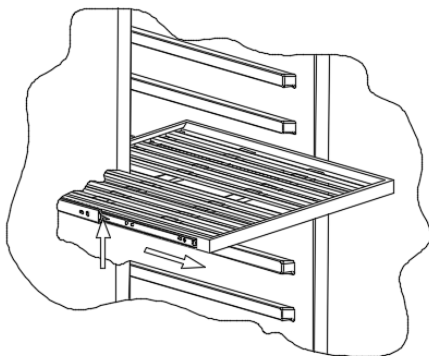
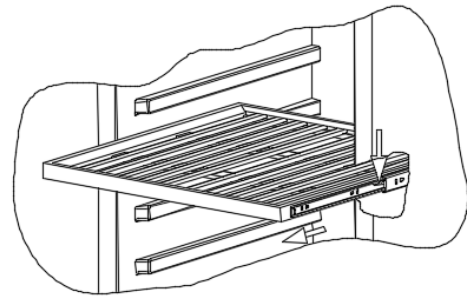


Figure 3



## 3-3 WOODEN SHELVES:

(Model: AWC241TDZ)

1. Open the door completely.
2. Remove all of the contents loaded on the shelf, if applicable.
3. Line up the shelf notches with the rail posts as indicated below. This will require you to hold on to both rails as you move the shelf to line up the posts with the notches on both sides of the shelf.
4. Evenly lift the shelf up and then pull the shelf out. (Figure 4)

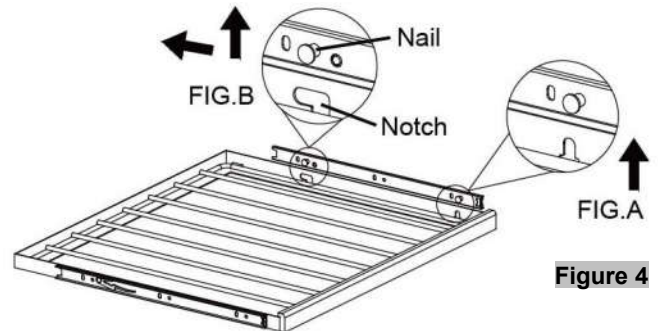


Figure 4

- Open the door completely.
- If necessary, make sure you remove all the contents sitting on the shelf..
- Pull the shelf forward until the notch aligns with the plastic post on each side of the shelf track.
- Lift the shelf until both notches pass through the posts. Continue to pull the shelf forward until it is completely removed from the inner compartment. (Figure 5)

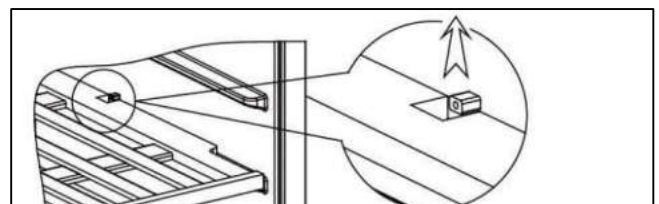


Figure 5



# 3. DISASSEMBLY

## 3-4 TOP LAMP

(Models: AWC151DZ, AWC241DZ, AWC241TDZ)

1. Loosen four screws. (figure 6)

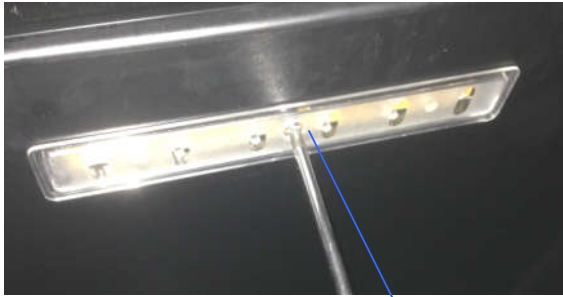


Figure 6

screw

2. Unplug the led light connector. (figure 7)



Figure 7

connector

3. Loosen four screws. (figure 8)

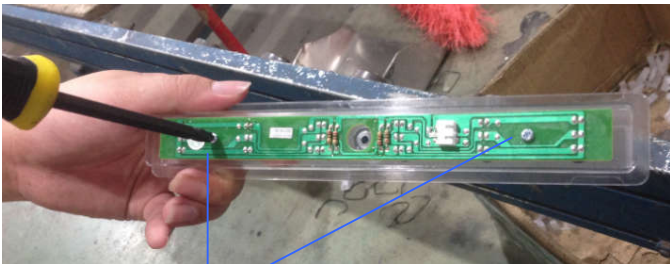


Figure 8

screw

4. Pull out the LED light. The LED is pictured below. (figure 9)



Figure 9

## 3-5 BROADSIDE LAMP

(Models: AWC151DZ, AWC241DZ, AWC241TDZ.)

1. Pull the lamp cover.
2. Separate the claw fixed to the LED light. Separate the lead wire housing. (figure 10)

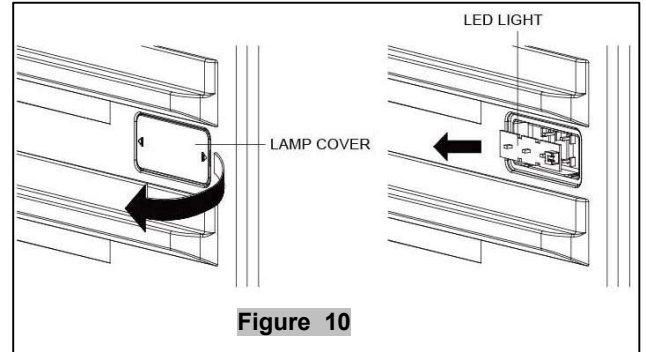


Figure 10

3. The LED light is pictured below. (figure 11)

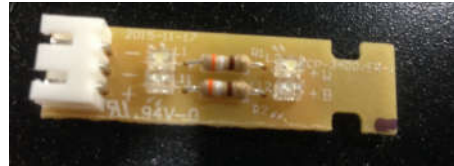


Figure 11

## 3-6 DISPLAY BOARD &

(Models: AWC151DZ)

1. Loosen four screws. (figure 12)

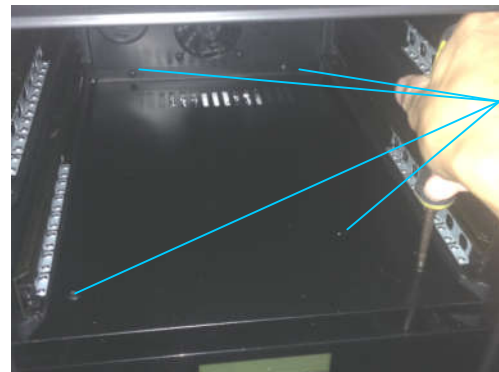


Figure 12

screw

2. Lift up the cover and pull it out.. (figure 13)



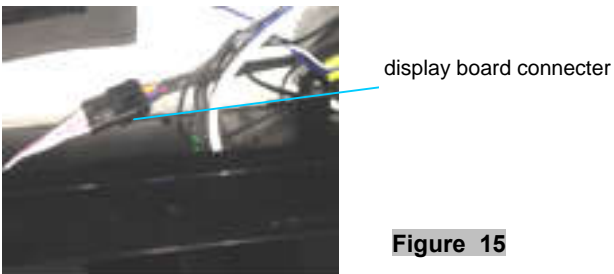
Figure 13

# 3. DISASSEMBLY

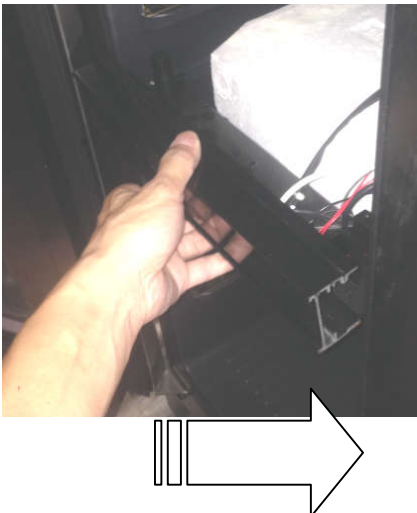
3. Loosen two screws. (figure 14)



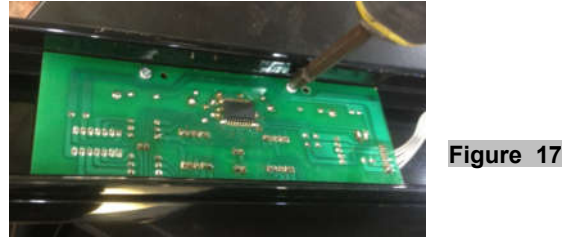
4. Find out the display board connector. (figure 15)



5. Pull out the air duct board assembly from the cabinet, then remove the front display support bracket from right side (figure 16)



6. Loosen two screws. (figure 17)

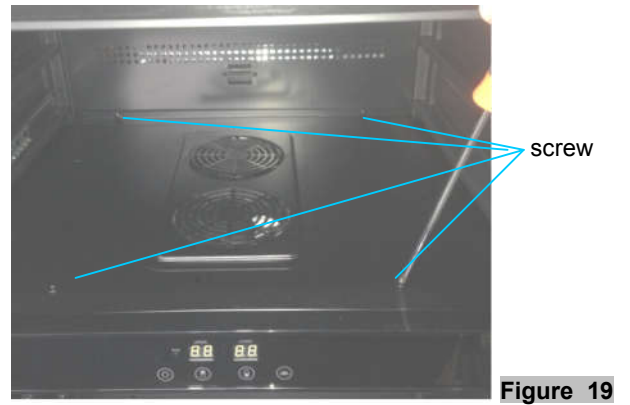


7. The display board is pictured below. (figure 18)



(Models: AWC241DZ)

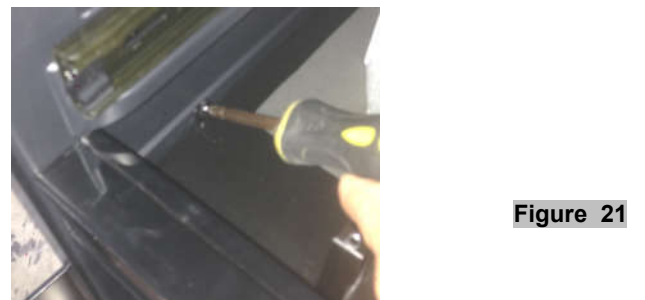
1. Loosen four screws. (figure 19)



2. Lift up the cover and pull it out. (figure 20)

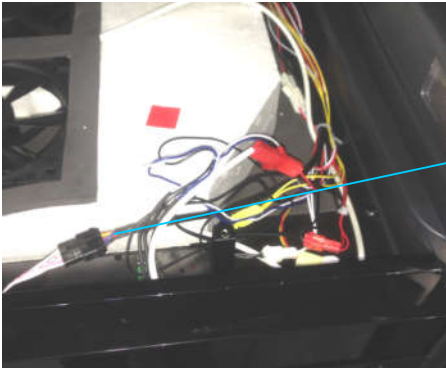


3. Loosen two screws. (figure 21)



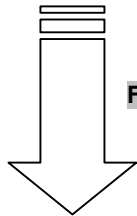
# 3. DISASSEMBLY

4. Find out the display board connector. (figure 22)

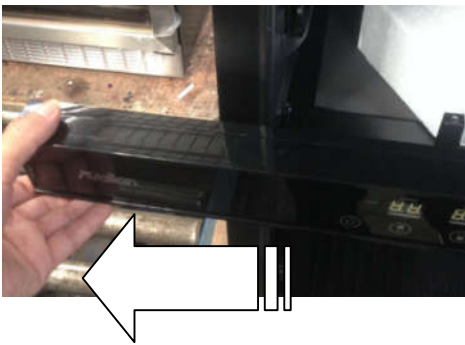


**Figure 22**  
connector

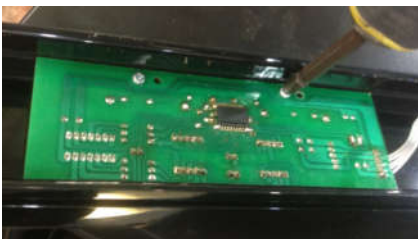
5. Pull out the air duct board assembling from the cabinet, then remove the front display support bracket from left side (figure 23)



**Figure 23**



6. Loosen two screws. (figure 24)



**Figure 24**

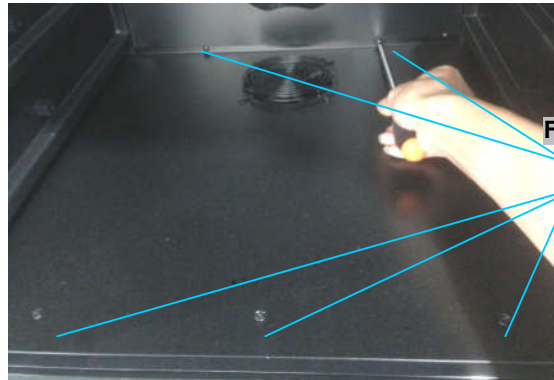
7. The display board is like below. (figure 25)



**Figure 25**

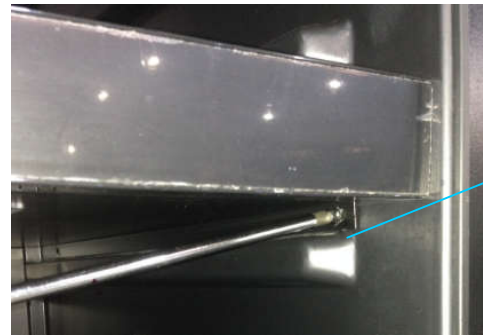
(Models: AWC241TDZ)

1. Loosen five screws. (figure 26)



**Figure 26**  
screw

2. Remove two screws from both side of air duct board C (figure 27)



**Figure 27**  
screw

3. Remove screws from the lower side of air duct board C (figure 28)



**Figure 28**  
screw

4. Lift up the air duct board B cover and pull it out (figure 29)



**Figure 29**



# 3. DISASSEMBLY

5. Find out the display board connector (figure 30)



Figure 30

6. Pull out the air duct board assembling from the cabinet, then remove the front display support bracket from left side. (figure 31)

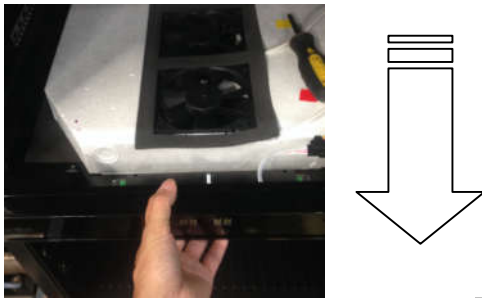
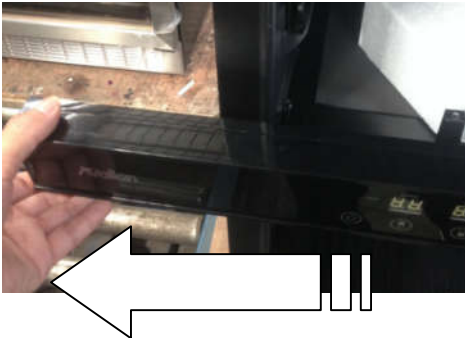


Figure 31



7. Loosen two screws. (figure 32)



Figure 32

8. The display board is like below. (figure 33)



Figure 33

## 3-5 CONTROL BOARD & TRANSFORMER (Models: AWC151DZ)

1. Loosen three screws. (figure 34)



Figure 34

2. The power board & transformer are like below. (figure 35)

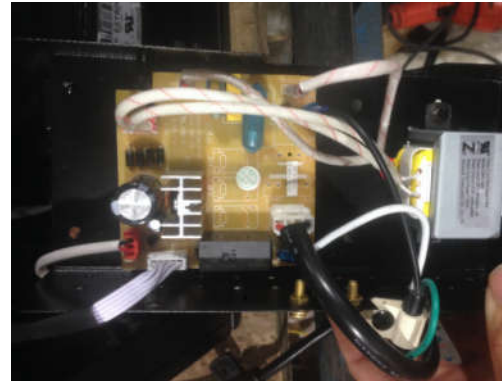


Figure 35

## (Models: AWC241DZ, AWC241TDZ)

1. Loosen three screws. (figure 36)



Figure 36

2. The power board & transformer are like below. (figure 36)

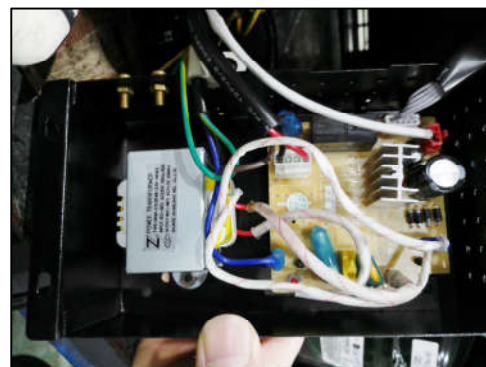


Figure 36

# 3. DISASSEMBLY

## 3-6 SENSOR & FAN

(Models: AWC151DZ)

1. Loosen six screws. Pull out the rear air duct cover. (figure 37)

Carbon Filter

fan

Screw

Sensor



Figure 37

2. Loosen 1 screw to replace the sensor & fan. (figure 38)

wire housing

PTC Heater

screw

evaporator

defrost sensor



Figure 38

(Models: AWC241DZ)

1. Loosen six screws. Pull out the rear air duct cover. (figure 39)

Screw

fan

cold catalyst

Sensor



Figure 39 - 10

2. Loosen 1 screw to replace the sensor & fan. (figure 40)

evaporator

defrost sensor

wire housing screw

PTC Heater

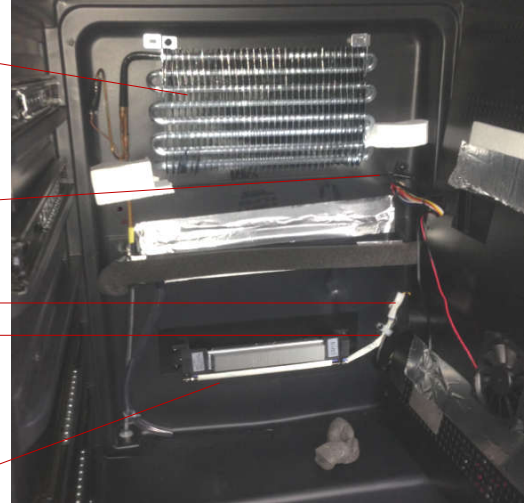


Figure 40

(Models: AWC241TDZ)

1. Loosen screws. Pull out the rear air duct cover. (figure 41)

sensor

fan

cold catalyst

Sensor

fan

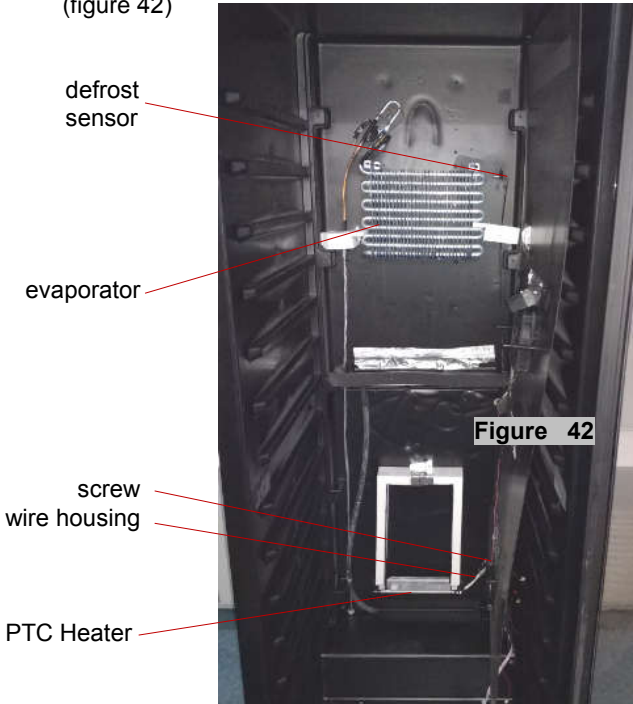
screw



Figure 41

# 3. DISASSEMBLY

- Loosen 1 screw to replace the sensor & fan. (figure 42)



## 3-7 COMPRESSOR PTC STARTER & OVERLOAD PROTECTOR

(Models: AWC151DZ, AWC241DZ)

- Open the box near compressor, The starter and overload protector are located inside. (figure 43)



Figure 43

- Dismantle the compressor PTC starter and overload protector. (figure 44)

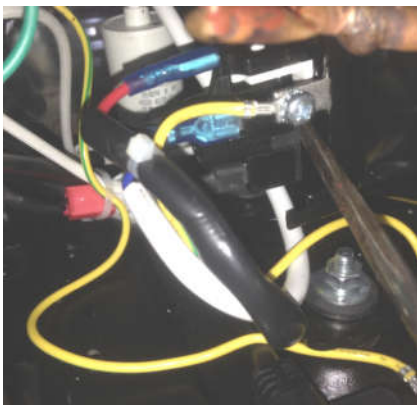


Figure 44

- The compressor PTC starter and overload protector is like below. (figure 45)



Figure 45

(Models: AWC241TDZ)

- Open the box near compressor, The starter and overload protector are located inside.(figure 46)



Figure 46

- Remove the compressor junction box. (figure 47)

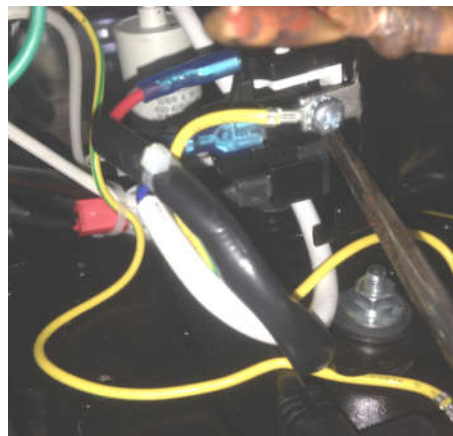


Figure 47



# 3. DISASSEMBLY

3. The compressor PTC starter and overload protector is pictured below. (figure 48)

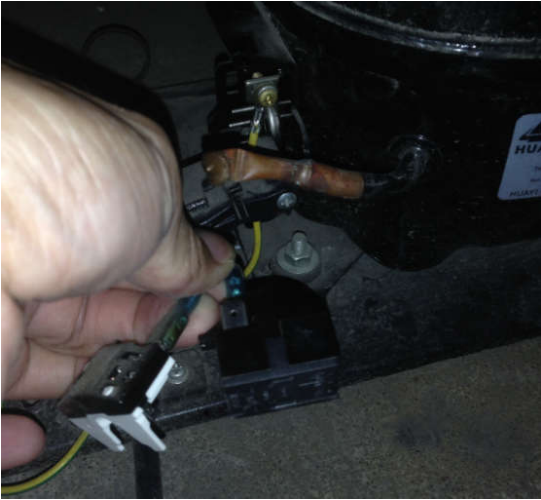
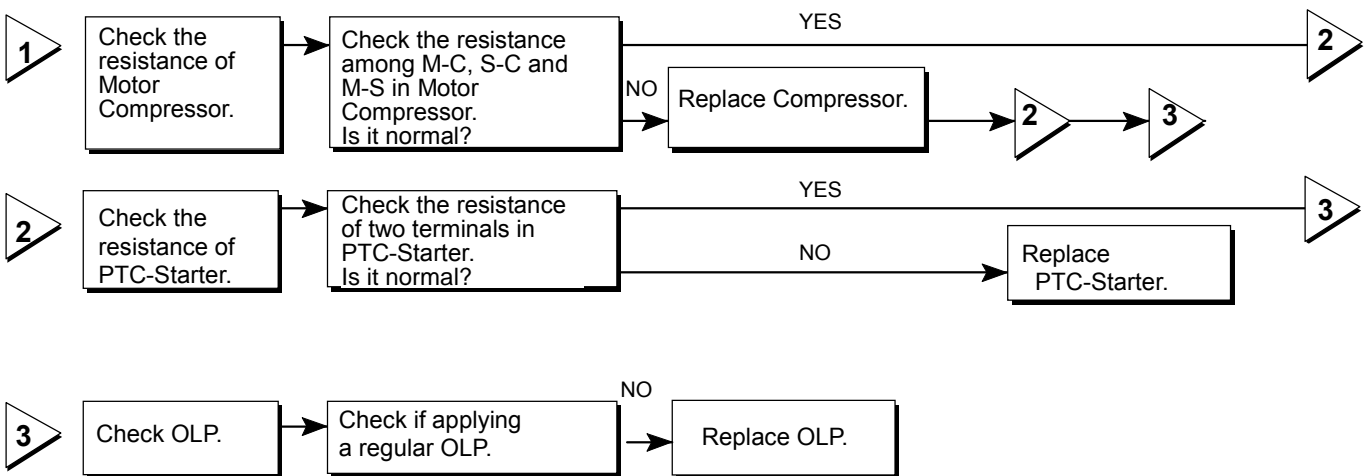


Figure 48

# 4. TROUBLESHOOTING

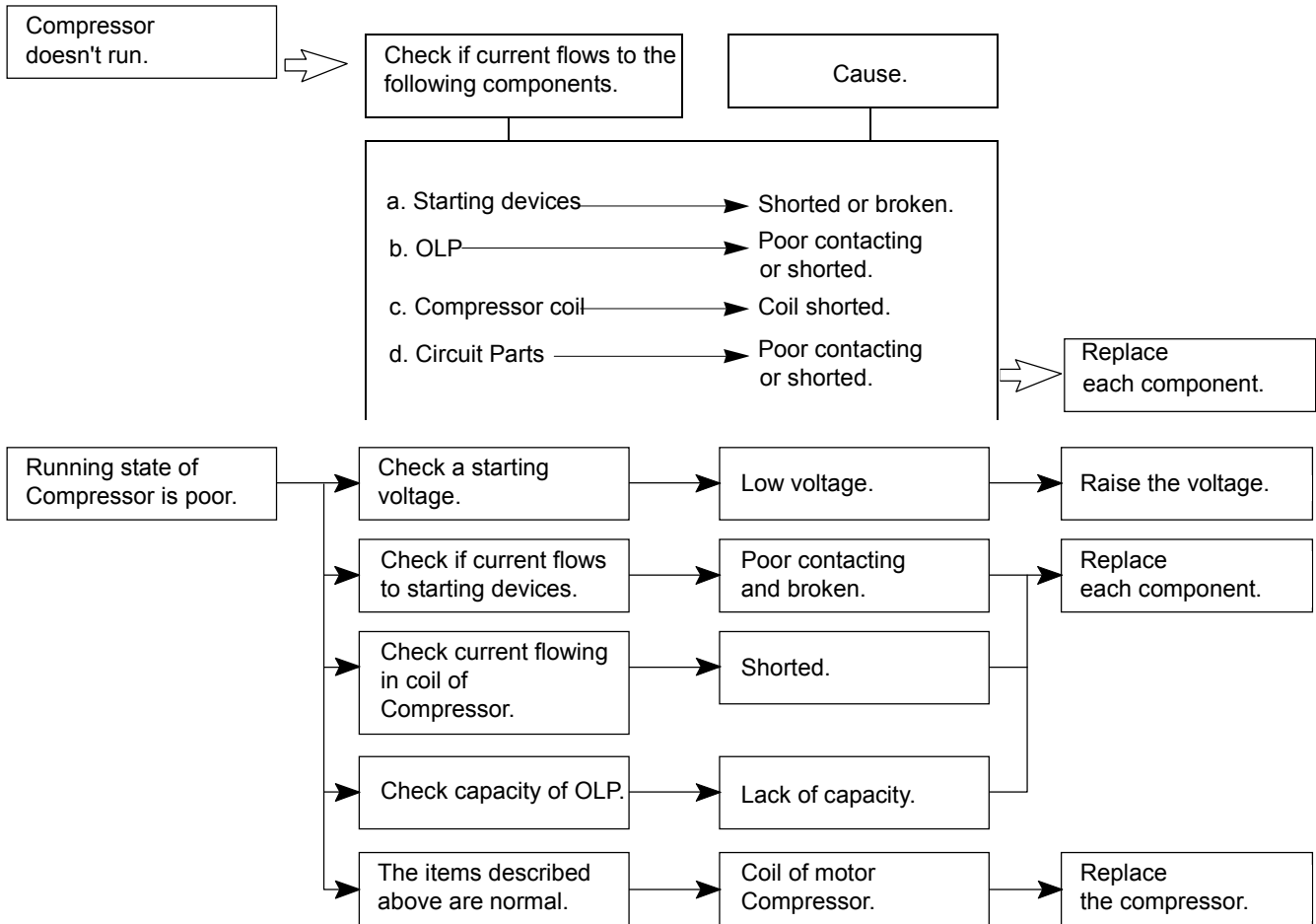
## 4-1 COMPRESSOR COMPONENTS



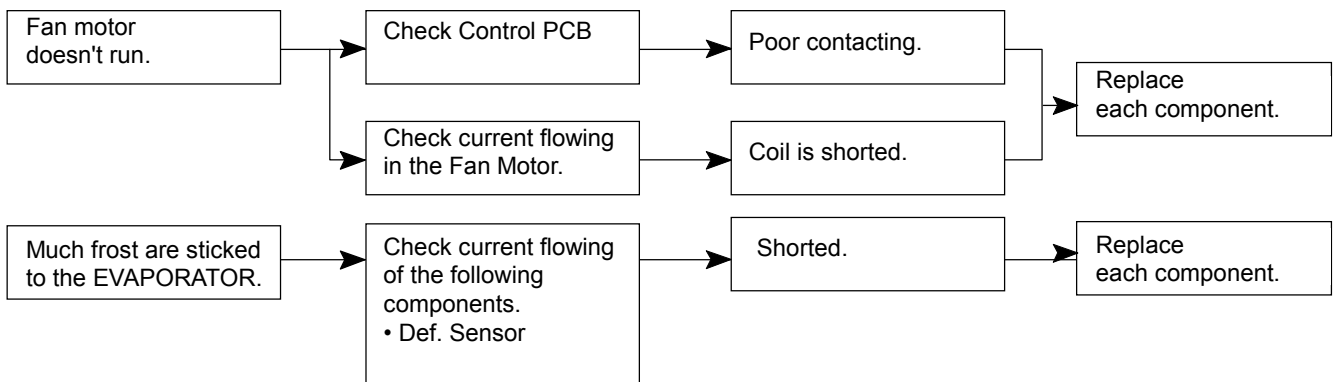
# 4. TROUBLESHOOTING

## 4-2 OTHER ELECTRIC COMPONENTS

### ▼ Not Cooling



### ▼ Cooling ability is poor





# 4. TROUBLESHOOTING

## 4-3 SERVICE DIAGNOSIS CHART

Problem	Possible Cause
Appliance does not operate.	Not plugged in. The appliance is turned off. The circuit breaker tripped or a blown fuse.
Appliance is not cold enough.	Check the temperature control setting. External environment may require a higher setting. If ambient room temp too high, adjust control setting. The door is opened too often. The door is not closed completely. The door gasket does not seal properly.
Turns on and off frequently.	The room temperature is hotter than normal. A large amount of contents has been added to the appliance. The door is opened too often. The door is not closed completely. The temperature control is not set correctly. The door gasket does not seal properly.
The light does not work.	Not plugged in. The circuit breaker tripped or a blown fuse. The bulb has burned out. The light button is "OFF". Energy conservation button is on.
Vibrations.	Check to assure that the appliance is level.
The appliance seems to make too much noise.	The rattling noise may come from the flow of the refrigerant, which is normal. As each cycle ends, you may hear gurgling sounds caused by the flow of refrigerant in your refrigeration appliance. Contraction and expansion of the inside walls may cause popping and crackling noises. The appliance is not level.
The door will not close properly.	The appliance is not level. The door was reversed and not properly installed. The gasket is dirty. The shelves are out of position.
Display error code "E1"	The air sensor has an open circuit. Connection to main control PCB is with yellow color wires. Check the circuit, if it is normal, the sensor may need to be replaced.
Display error code "E2"	The air sensor has a short circuit. Connection to main control PCB is with yellow color wires. Check the circuit, if it is normal, the sensor may need to be replaced.
Display error code "E3".	The defrost sensor has an open circuit. Connection to main control PCB is with red color wires. Check the circuit, if it is normal, the sensor may need to be replaced.
Display error code "E4".	The defrost sensor has a short circuit. Connection to main control PCB is with red color wires. Check the circuit, if it is normal, the sensor may need to be replaced.
Display error code "E7".	The air sensor has an open circuit. Connection to main control PCB is with white color wires. Check the circuit, if it is normal, the sensor may need to be replaced.
Display error code "E8".	The air sensor has a short circuit. Connection to main control PCB is with white color wires. Check the circuit, if it is normal, the sensor may need to be replaced.

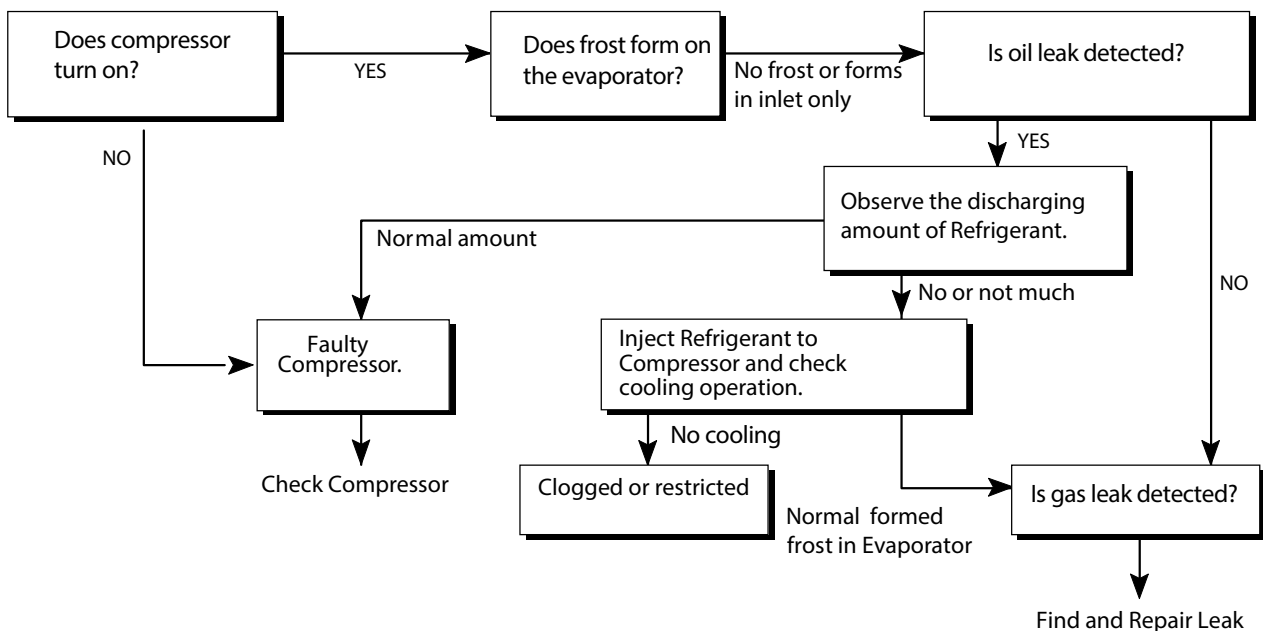
# 4. TROUBLESHOOTING

## 4-4 REFRIGERATING CYCLE

### ▼ Troubleshooting Chart

CAUSE	STATE OF UNIT	STATE OF EVAPORATOR	TEMPERATURE OF COMPRESSOR	COMMENTS	
LEAKAGE	PARTIAL LEAKAGE	Appliance does not get cold enough	Low flowing sound of Refrigerant is heard and frost forms	A little high - more than ambient room temperature.	<ul style="list-style-type: none"> <li>• A little refrigerant discharges</li> <li>• Normal cooling is possible when charging refrigerant of regular amount stated on specification plate / rating label.</li> </ul>
	WHOLE LEAKAGE	Appliance does not get cold at all	Flowing sound of Refrigerant is not heard and frost isn't formed.	A little high - more than ambient room temperature.	<ul style="list-style-type: none"> <li>• A little refrigerant discharges</li> <li>• Normal cooling is possible when charging refrigerant of regular amount stated on specification plate / rating label.</li> </ul>
CLOG IN CAPILLARY	PARTIAL RESTRICTION	Appliance does not get cold enough	Flowing sound of Refrigerant is heard and frost forms	A little high - more than ambient room temperature.	<ul style="list-style-type: none"> <li>• No discharging of refrigerant</li> <li>• The capillary tube is faulty.</li> <li>• The filter dryer is faulty.</li> <li>• The condensor is faulty.</li> <li>• The evaporator is faulty.</li> </ul>
	WHOLE RESTRICTION	Appliance does not get cold	Flowing sound of Refrigerant is not heard and frost isn't formed.	A little high - more than ambient room temperature.	<ul style="list-style-type: none"> <li>• No discharging of refrigerant</li> </ul>

Observe refrigerant discharging point. Oil discharge/stain is often best indicator. Use bubbles to locate hole in line, evaporator or condensor.



# 5. DESCRIPTION OF PCB

(Models: AWC151DZ AWC241DZ AWC241TDZ)

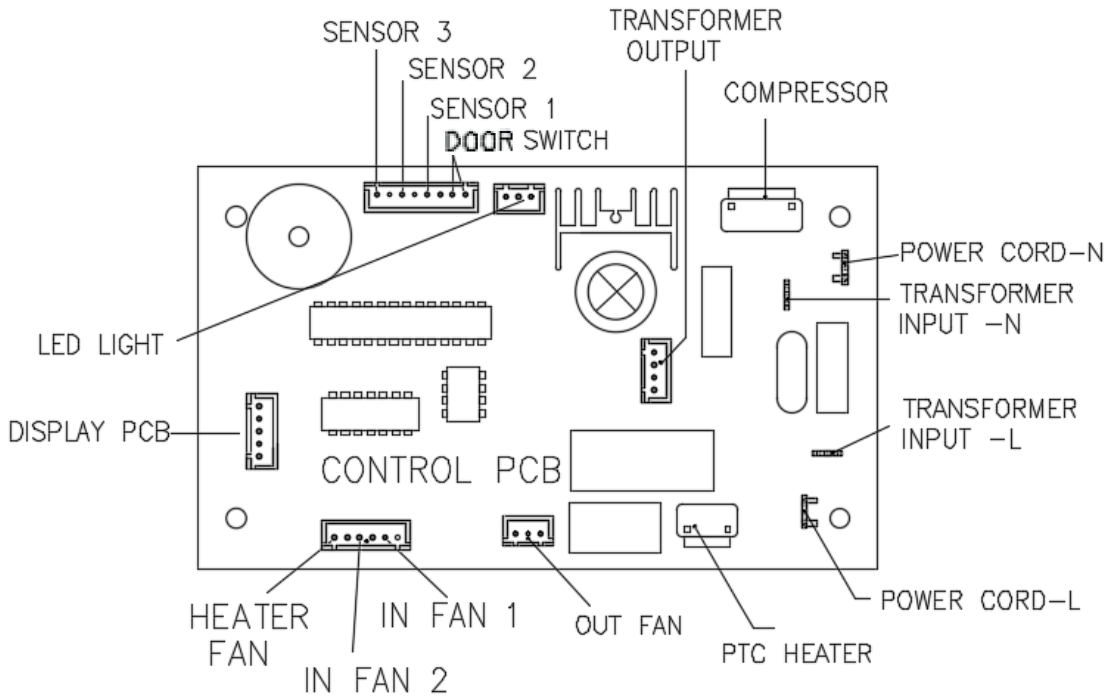


Figure 56

<b>DATE</b>	<b>REVISION NOTES:</b>
9/22/2017	Initial Document
10/16/2017	Minor text and title edits
10/27/2017	Text edits
12/19/2017	Formatting edits