

EDGESTAR

Ice Cream Maker

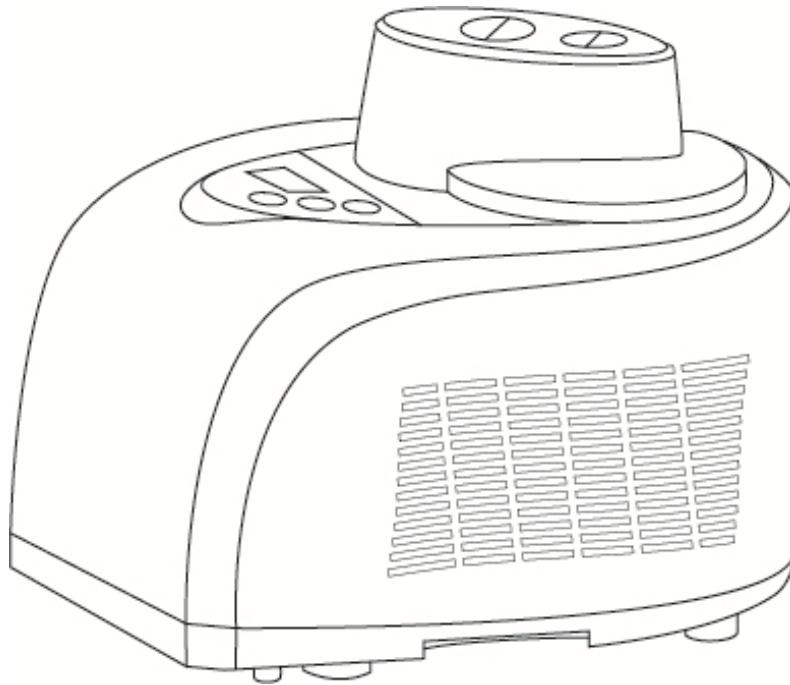

ICM301SS

Owner's Manual

For more information on other great EdgeStar products on the web, go to <http://www.edgestar.com>

Important Safety Information

Improper handling can cause serious damage to the EdgeStar ice cream maker and/or injury to the user. This ice cream maker is designed for domestic indoor use only. Do not use this unit for industrial or commercial use. Any other use may invalidate the warranty. Please review the ratings label located on the rear panel of the unit for electrical and other technical data related to this unit. This unit must be used in a properly grounded wall outlet. Please read and follow the safety information listed below to reduce the risk of fire, electric shock or injury.



Electrical Safety

- Do not exceed the power outlet ratings.
- It is recommended that the ice cream maker be connected on its own circuit.
- A standard electrical supply (115 V, 60Hz), that is properly grounded in accordance with the National Electrical Code and local codes and ordinances is required.
- Use outlets that cannot be turned off by a switch or pull chain.
- Always turn the unit off and unplug it from the outlet when cleaning.
- Unplug the unit if it is not going to be used for an extended period of time.
- Do not operate the unit with a power plug that is missing the ground plug, a damaged cord or a loose socket.
- Be sure the ice cream maker is properly grounded.
- Never plug or unplug the unit with wet hands.
- Do not bypass, cut or remove the grounding plug.
- Do not use extension cords or power strips with this unit. You may need to contact your electrician if it is necessary to use a longer cord or if you do not have a grounded outlet. Do not modify the power cord's length or share the outlet with other appliances. If you must use an extension cord, use No.14AWG minimum size and rated no less than 1875 watts.
- Do not start or stop the unit by switching the circuit's power on and off.
- If the power cord is damaged, it must be replaced by the manufacturer or a qualified technician.
- Never repair the unit while it is plugged in.
- Immediately unplug the unit if it makes strange sounds, emits an odor or smoke comes out of it, and contact customer service.
- Do not remove any part of the casing unless instructed by an authorized technician.
- You should never attempt to repair the unit yourself.
- Contact EdgeStar Support if the unit needs repair service.
- Do not tip the unit over while the power is on.



General Safety

- Install the ice cream maker in a well ventilated area where the ambient temperature is above 50°F and below 90°F.
- This unit is designed to be used indoors, and protected from rain, sleet, snow, etc. Do not use your ice cream maker outdoors. Place the ice-maker away from direct sunlight.
- This unit is not intended to be used by children and should be supervised to ensure that they do not play with this product.
- Do not use this appliance near flammable gas or combustibles, such as gasoline, benzene, thinner, etc.
- Do not place the unit near heat sources such as ovens and grills.
- Only use in an upright position on a flat, level surface and provide proper ventilation.
- If the unit has not been used for an extended period, thoroughly clean it before using it.
- Do not leave any cleaning solutions in or on the unit
- Do not use solvent-based cleaning agents or abrasive solutions on the interior as they may transmit taste to the ice cream and damage the interior.
- Do not clean the unit with flammable fluids. The fumes can create a fire hazard or cause an explosion.
- This appliance is not intended for use by persons, including children, with reduced physical, sensory or mental capabilities, unless they have been given supervision or instruction concerning the use of the appliance by the person(s) responsible for their safety.

Table of Contents

IMPORTANT SAFETY INFORMATION	1
INTRODUCTION	1
PARTS IDENTIFICATION	2
BEFORE YOU BEGIN: PREPARING THE ICE CREAM MAKER	3
Unpacking the Ice Cream Maker	3
Cleaning the Ice Cream Maker	3
Installation Requirements	3
Clearance and Environment Requirements	3
Electrical Requirements.....	3
OPERATION	4
Using Your Ice Cream Maker	4
Connect to the Electricity	4
Using the Control Panel	4
How to make Ice Cream	5
Extended Cooling Function	5
Prevent Capacity Overflow	6
Transfer Your Ice Cream	6
CLEANING AND MAINTENANCE	6
Ice Cream Recipes	7
SPECIFICATIONS	14
LIMITED WARRANTY	15

This is an automatic self-refrigerated frozen ice cream & sorbet maker.
For your safety and continued enjoyment of this product, please read the
instructions carefully before using.

Introduction

Thank you for purchasing this EdgeStar ice cream maker. We are glad you chose us. We believe that your purchase of this product opens a relationship between you and EdgeStar. We will provide the customer support needed to nurture that relationship.

This manual contains important information regarding the proper installation, use and maintenance of your ice cream maker. Following this manual will ensure that your product will work at its peak performance and efficiency.

Please save the original product packaging in case you need to safely transport your portable ice cream maker.

For Your Records:

Please write down the model number and serial number below for future reference. Both numbers are located on the ratings label on the back of your unit and are needed to obtain warranty service. You may also want to staple your receipt to this manual as it is the proof of your purchase, and is also needed for service under your warranty.

Model Number: _____

Serial Number: _____

Date of Purchase: _____

To better serve you, please do the following before contacting customer service:

- If you received a damaged product, immediately contact the dealer that sold you the product.
- Read and follow this instruction manual carefully to help you install, use and maintain your ice cream maker.
- Read the troubleshooting section of this manual as it will help you diagnose and solve common issues.
- Visit us on the web at <http://www.edgestar.com> to register your product, download product manuals, and access additional troubleshooting resources and up-to-date information.
- If you need warranty service, our friendly customer service representatives are available via email at service@edgestar.com or by telephone at **1 (866) 319-5473**.

Parts Identification

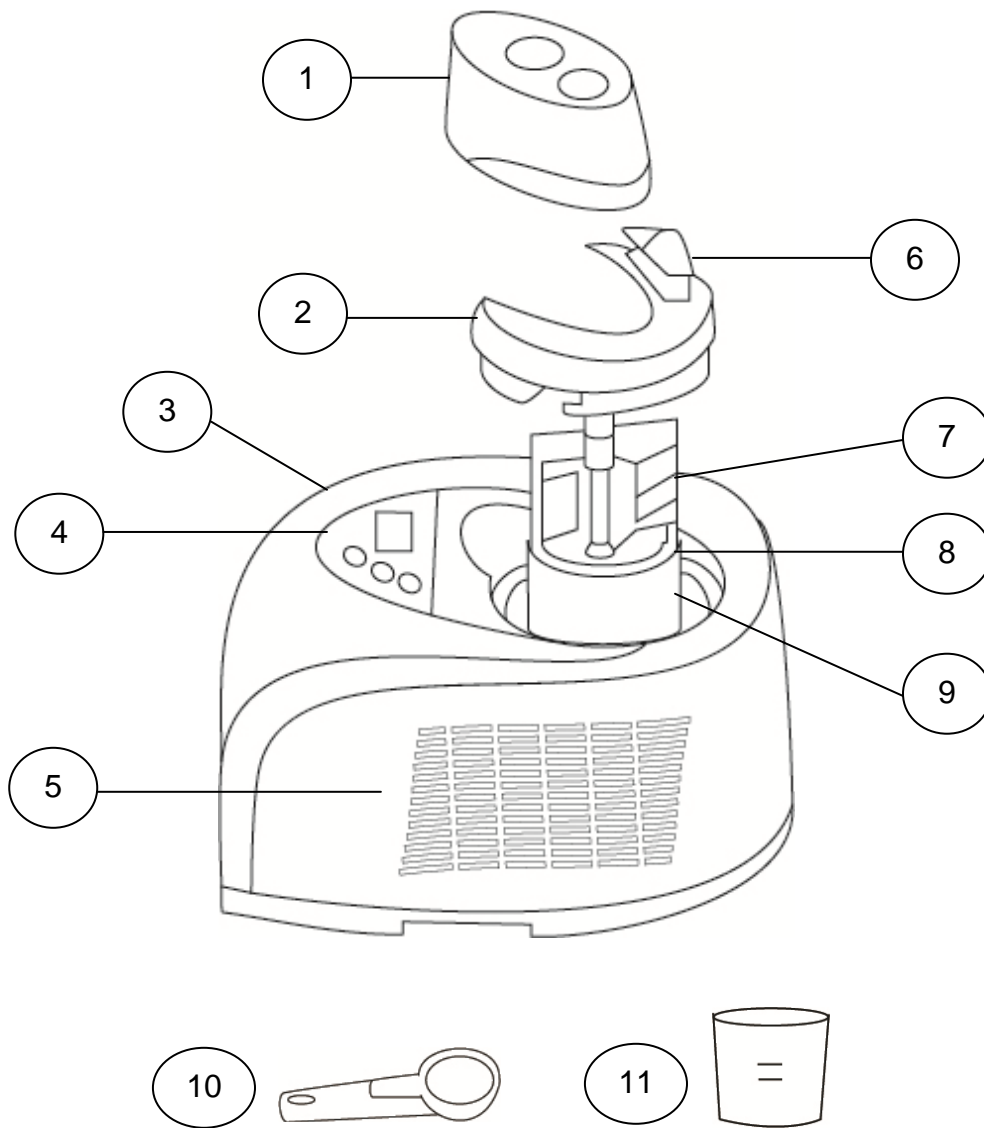

PARTS KEY

- | | |
|--------------------|-------------------|
| 1. Blender Motor | 7. Mixing Blade |
| 2. Transparent Lid | 8. Removable Bowl |
| 3. LCD Display | 9. Fixed Bowl |
| 4. Control Panel | 10. Scoop |
| 5. Air Vent | 11. Measuring Cup |
| 6. Refill Lid | |



IMPORTANT: Do not remove any safety, warning, or product information labels from your ice cream maker.

Before you Begin: Preparing the Ice Cream Maker for Use

Unpacking the Ice Cream Maker

Carefully remove the packaging materials. Remove any shipping tape and glue from your ice cream maker before using. Do not use sharp instruments, rubbing alcohol, flammable fluids, or abrasive cleaners to remove tape or glue. These products can damage the surface of your ice cream maker. Check to make sure the bowl, mixing blade, spoon and measuring cup are included. If any parts are missing, please contact our customer service. Put the ice cream maker on a level and flat surface away from direct sunlight and other sources of heat such as a stove, furnace, radiator, etc. The appliance must be positioned so that the power plug is accessible.

Cleaning the Ice Cream Maker

Follow the Cleaning and Maintenance section to clean the ice cream maker.

Installation Requirements

The ice cream maker has been designed for free-standing installation which will allow you to install the unit in almost any place you desire provided you level the unit and follow the instructions for clearance and electrical requirements.

Clearance and Environment Requirements

- Choose a well ventilated indoor area.
- This unit **MUST** be placed in an area protected from the elements, e.g., wind, rain, water spray or drips. The ice cream maker should not be located next to ovens, grills or other high heat sources.
- The unit should be located on a firm and level surface

Electrical Requirements

Read all safety precautions listed at the beginning of this manual. It is recommended that a separate circuit serving only your ice cream maker be provided. Use receptacles that cannot be turned off by a switch or pull chain.

The ice cream maker is equipped with a power supply cord having a 3-prong grounding plug. To minimize possible shock hazard, the cord must be plugged into a mating 3-pronged and grounding-type wall receptacle providing 110-120V, 60Hz, grounded in accordance with the National Electrical Code and local codes and ordinances. If a mating wall receptacle is not available, it is the personal responsibility of the customer to have a properly grounded, 3-prong wall receptacle installed by a certified electrician.

- **Important:** Always place the Ice Cream Maker upright on a flat surface in order that the built-in compressor can provide best performance.



WARNING! Do not, under any circumstances, cut or remove the third (ground) prong from the power cord.

Operation

Using Your Ice Cream Maker

Before using your ice cream maker it is strongly recommended to clean it thoroughly. Read and follow the Cleaning and Maintenance section of the manual before proceeding.

Follow the steps below to start using your ice cream maker.

1. Place the removable mixing bowl into the fixed bowl.
2. Insert the mixing blade into the removable mixing bowl.
3. Place the transparent lid on top of both the fixed and removable bowls and keep the mixing blade fitted in the center of the transparent lid.
4. Insert the refill lid onto the transparent lid.
5. Lastly mount the blender motor onto the transparent lid and be sure that the motor axis is fitted into the hole on top of the mixing blade.

CAUTION: Do not use voltage different from the recommended one.

Connect to the Electricity

Check voltage indicated on the rating label, make sure it matches with the National Electric Code and local code, then plug into the socket.

Using the Control Panel

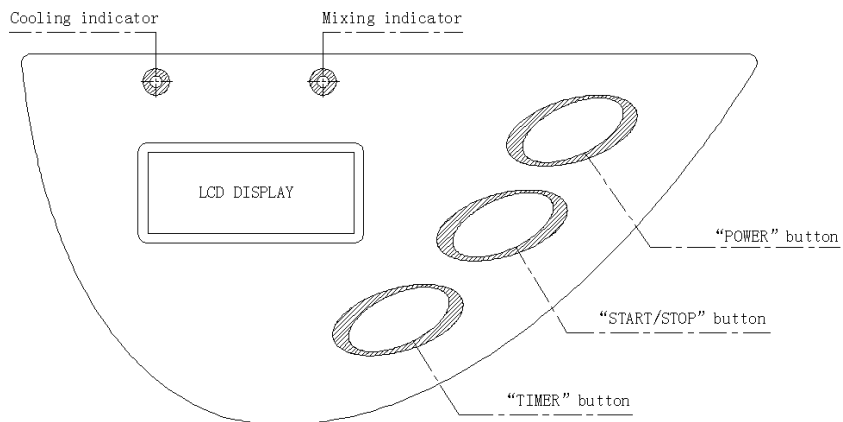

[POWER] Button: Press this button to turn appliance on. Default operating time "60:00" minutes will be shown on LCD display.

[TIMER] Button: Press this button to change time for the desired setting.

[START/STOP] Button: Press this button to start/stop the appliance.

How to make Ice Cream

Turn the (Power) button on. Preset desired time to 10, 20, 30, 40, 50 or 60 minutes.

After the timer is set, press [START/STOP] button to start. The ice cream maker will begin mixing and cooling immediately and both indicators will light up. The ice cream maker will stop automatically and beep 10 times when the time is up and the ice cream is ready to serve.

If the ice cream is not served or the appliance is not turned off in 10 minutes, it will automatically enter into an "Extended Cooling Function" to keep the ice cream at its proper temperature.

Compressor self-protection function:

- 1) If the POWER button is pressed during the ice cream making process, the appliance will automatically be set to 3 minutes. After 3 minutes, the appliance will start again. The mixing function and cooling function will start simultaneously. If, during the 3 minute countdown, the POWER button is pressed again, the mixing function will start immediately. The cooling function will only start after the end of the countdown.
- 2) If the appliance experiences a power failure or is unplugged during the ice cream making process, you need to restart the appliance after 3 minutes. Otherwise, it will enter into compressor self-protection status.

CAUTION: Always remember to unplug from outlet when you serve the finished ice cream to avoid an electric shock.

Extended Cooling Function

The ice cream maker automatically runs the COOLING function(no mixing) every other 10 minutes for an hour. After 1 hour, it returns to the initial default setting (power on with no operation).

Adjust Ice Cream Maker Settings

Interrupt Ice Cream Maker: You can stop the appliance by pressing down the [START/STOP] button for 3 seconds, or press the [Power] button once when the appliance is running.

Adjust Time Setting: You can add operating time by pressing the (timer) button repeatedly. A 5 minute increment will be added to the timer each time you press the button until it reaches 60 minutes.

Modify Ice Cream Texture (After Operating Time Finished)

When the preset time finishes, the appliance stops and returns to the initial default setting. If you prefer a harder texture, you can select an operating time again (10/20/30/40/50/60 minutes) by pressing the [TIMER] button, and then press the [START/STOP] button. The appliance will run the extra time you selected and then enters into the "Extended Cooling Function" when the time is up to keep the ice cream chilled.

Prevent Capacity Overflow

To avoid overflow, make sure the ingredients do not exceed 80% of the removable mixing bowl capacity (Ice cream expands when being formed)

Transfer Your Ice Cream

Transfer finished ice cream into another container using a plastic scoop or a wooden spoon. Do not use a metal scoop to avoid scratches inside the removable mixing bowl.



The ice cream maker must be thoroughly cleaned if it has been left unused for a long time. Follow carefully any instructions provided for cleaning or use of sanitizing solution. Do not leave any solution inside the ice cream maker after cleaning.



If the ice cream maker will not be used for an extended period of time, you should unplug the unit from power and dry the interior with a clean soft cloth.

CLEANING AND MAINTENANCE

Cleaning after each use and proper maintenance will ensure efficiency, top performance, and long life.

Never use a solvent-based cleaning agent. These cleaners may transmit taste to the ice cream, or damage and discolor the interior.

Unplug the unit before cleaning the exterior and interior.

Before using your ice cream maker, you are strongly recommended to clean it thoroughly.

1. Wash all parts that come into contact with the ice cream (including the fixed bowl, removable mixing bowl, mixing blade, transparent lid, refill lid, measuring cup and spoon).
2. Clean the interior with a diluted cleaning solution, warm water and a soft cloth. (DO NOT use any caustic or abrasive solutions) (Do not clean your ice maker with flammable fluids.)
3. The outside of the ice maker should be cleaned after each use with a mild detergent and warm water.
4. Dry the interior and exterior with a soft cloth.

Routine maintenance

Take out all the removable parts from the ice cream maker, take out the mixing blade and wipe with a damp cloth.

- (1) Take out the removable mixing bowl, wipe with a damp cloth. Do not use abrasive solutions or cleaning tools.
- (2) Wipe the blending motor with a damp soft cloth. Keep away from water. Do not immerse the motor in water and keep the ventilation vent dry at all time.
- (3) Clean the ice cream maker a diluted cleaning solution, warm water and a soft cloth. Do not immerse the appliance in water. Keep the ventilation vent dry at all time. Dry all the parts with a soft dry cloth and install them back in the ice cream maker..

- Do not touch the power plug when your hands are wet.
- Never unplug the unit by pulling on the plug.

ICE CREAM RECIPES

VANILLA ICE CREAM

Makes ten 1/2-cup servings.

1 cup whole milk

3/4 cup granulated sugar

2 cups heavy cream

1 /2 teaspoons pure vanilla extract, to taste

In a medium bowl, use a hand mixer or a whisk to combine the milk and granulated sugar until the sugar is dissolved, about 1 – 2 minutes on low speed. Stir in the heavy cream and vanilla to taste. Turn the machine ON, pour mixture into freezer bowl through ingredient spout and let mix until thickened, about 50 – 60 minutes.

Nutritional analysis per serving:

Calories 239 (68% from fat) . carbo. 17g . pro 2g . fat 18g . sat. fat 11g . chol. 69mg . sod. 30mg

VARIATIONS:

Mint Chip: Omit the vanilla and replace with 1 to 1-1/2 teaspoons pure peppermint extract (to taste). Chop your favorite 4-ounce bittersweet or semi-sweet chocolate bar into tiny uneven pieces. Add the chopped chocolate during the last 5 minutes of mixing.

Butter Pecan: Melt 1 stick unsalted butter in a 10-inch skillet. Add 1 cup roughly chopped pecans and 1 teaspoon kosher salt. Cook over medium-low heat, stirring frequently until the pecans are lightly browned. Remove from the heat, strain (the butter will have a pecan flavor and may be reserved for another use). Allow the pecans to cool completely. Add the toasted buttered pecans during the last 5 minutes of mixing.

Cookies & Cream: Add 3/4 cup coarsely chopped cookies or your favorite candy (chocolate chip, Oreos., Mint Oreos., etc.) during the last 5 minutes of mixing.

BASIC CHOCOLATE ICE CREAM

Makes ten 1/2-cup servings.

1 cup whole milk

1/2 cup granulated sugar

240g or 8 ounces bittersweet or semi-sweet chocolate (your favorite), broken into 1/2-inch pieces

3/2 cups heavy cream

1 teaspoon pure vanilla extract

Heat the whole milk until it is just bubbling around the edges (this may be done on the stovetop or in a microwave). In a blender or food processor fitted with the metal blade, pulse to process the sugar with the chocolate until the chocolate is very finely chopped. Add the hot milk, process until well blended and smooth. Transfer to a medium bowl and let the chocolate mixture cool completely. Stir in the heavy cream and vanilla to taste.

Turn the machine ON, pour mixture into freezer bowl through ingredient spout and let mix until thickened, about 50 – 60 minutes.

Nutritional analysis per serving:

Calories 370 (60% from fat) . carbo. 34g . pro 3g . fat 25g .

sat. fat 11g . chol. 65mg . sod. 31mg

VARIATIONS:

Chocolate Almond: Add 1/2 teaspoon pure almond extract along with the vanilla. Add 1/2 - 3/4 cup chopped toasted almonds or chopped chocolate-coated almonds during the last 5 – 10 minutes of freezing.

Chocolate Cookie: Add 1/2 - 1 cup chopped cookies during the last 5 minutes of freezing.

Chocolate Fudge Brownie: Add 1/2 - 1 cup chopped day old brownies during the last 5 minutes of freezing. Chocolate Marshmallow Swirl: When removing the ice cream to a container for freezing, layer it with dollops of your favorite chocolate sauce and scoops of marshmallow crème (fluff).

EGGNOG ICE CREAM

Preparation: 5 – 10 minutes, 30 – 50 minutes chilling time; optional 2 hours to “marinate” in freezer.

Makes about ten 1/2-cup servings.

1/2 cup pasteurized egg product, such as EggBeaters.

3/4 cup sugar

1 cup whole milk

2 cups heavy cream

1 teaspoon rum extract

1 teaspoon brandy extract

1/2 teaspoon pure vanilla extract

1/8-1/4 teaspoon freshly grated nutmeg, to taste Combine the pasteurized egg product and sugar in a medium bowl and beat on medium speed with a hand mixer until thickened and pale yellow in appearance, about 1-1/2 to 2 minutes. Use low speed to stir in the whole milk, heavy cream, rum extract, brandy extract, and vanilla extract. Stir in the nutmeg to taste.

Turn the machine ON, pour mixture into freezer bowl through ingredient spout and let mix until thickened, about 25 – 30 minutes. The ice cream will have a soft creamy texture. If desired, transfer the ice cream to an airtight container and place in freezer until firm, about 2 hours to “ripen.”

Nutritional analysis per serving:

Calories 244 (67% from fat) .carbo. 17g .pro 3g . fat 17g . sat. fat 11g .

chol.69mg . sod. 46

FRESH STRAWBERRY ICE CREAM

Makes ten 1/2-cup servings.

250g or 1 pint fresh ripe strawberries, stemmed and sliced

3/2 tablespoons freshly squeezed lemon juice

1 cup sugar, divided

1 cup whole milk

2 cups heavy cream

1 teaspoon pure vanilla extract

In a small bowl, combine the strawberries with the lemon juice and 1/3 cup of the sugar; stir gently and allow to the strawberries to macerate in the juices for 2 hours.

In a medium bowl, use a hand mixer or a whisk to combine the milk and granulated sugar until the sugar is dissolved, about 1 – 2 minutes on low speed. Stir in the heavy cream plus any accumulated juices from the strawberries and vanilla. Turn the machine ON, pour mixture into freezer bowl through ingredient spout and let mix until thickened, about 50 – 60 minutes. Add the sliced strawberries during the last 5 minutes of freezing. Note: this ice cream will have a “natural” appearance of very pale pink; if a deeper pink is desired, sparingly add drops of red food coloring until desired color is achieved.

Nutritional analysis per serving:

Calories 222 (61% from fat) . carbo. 20g . pro 2g . fat 15g . sat. fat 10g . chol.57mg . sod.26mg

FRESH LEMON SORBET

Makes ten 1/2-cup servings.

2 cups sugar

2 cups water

1 cup freshly squeezed lemon juice

1 tablespoon finely chopped lemon zest *

Combine the sugar and water in a medium saucepan and bring to a boil over medium-high heat. Reduce heat to low and simmer without stirring until the sugar dissolves, about 3 – 5 minutes. Cool completely. This is called a simple syrup, and may be made ahead in larger quantities to have on hand for making fresh lemon sorbet. Keep refrigerated until ready to use.

When cool, add the lemon juice and zest; stir to combine. Turn the appliance ON, pour the lemon mixture into freezer bowl through ingredient spout and mix until thickened, about 50 – 60 minutes.

When zesting a lemon or lime use a vegetable peeler to remove the colored part of the citrus rind.

Nutritional analysis per serving:

Calories 204 (0% from fat) . carbo. 52g . pro .19g . fat 0g . sat. fat 0g . chol. 0mg . sod. 2mg

VARIATION:

Fresh Pink Grapefruit Sorbet: Substitute 1-1/2 cups freshly squeezed pink grapefruit juice for the lemon juice, and 1 tablespoon finely chopped grapefruit zest for the lemon zest. Add 1/4 cup Orgeat Syrup to the mixture (Orgeat Syrup is used for cocktails such as a MaiTai or Scorpion and can be found with the drink mixers in most grocery stores).

CHOCOLATE FROZEN YOGURT

Makes ten 1/2-cup servings.

1 cup whole milk

180g or 6 ounces bittersweet or semisweet chocolate, chopped

2 cups low-fat vanilla yogurt

1/4 cup sugar

Combine the milk and chocolate in a blender or food processor fitted with the metal blade and process until well blended and smooth, 20 – 30 seconds. Add the yogurt and sugar; process until smooth, about 15 seconds. Turn the appliance ON, pour mixture into freezer bowl through ingredient spout and let mix until thickened, about 50 – 60 minutes.

Nutritional analysis per serving:

Calories 222 (31% from fat) . carbo. 36g . pro 3g . fat 8g .

sat. fat .64g . chol. 4mg . sod. 46mg

PEPPERMINT STICK ICE CREAM

Preparation: 5 – 10 minutes, 30 – 50 minutes chilling time; optional 2 hours to “marinate” in freezer.

Makes about ten 1/2-cup servings.

1 cup whole milk, well chilled

3/4 cup granulated sugar

2 cups heavy cream, well chilled

1/2 teaspoons pure vanilla extract

1 teaspoon peppermint extract

3/4 cup crushed hard peppermint candies

In a medium bowl, use a hand mixer or a whisk to combine the milk and granulated sugar until the sugar is dissolved, about 1 – 2 minutes on low speed. Stir in the heavy cream, vanilla and peppermint extract. Turn the machine ON, pour mixture into freezer bowl through ingredient spout and let mix until thickened, about 25 – 30 minutes. Add the crushed peppermint candies during the last 5 minutes of mixing.

Nutritional analysis per serving:

Calories 282 (58% from fat) .carbo. 28g .pro 2g . fat 18g . sat. fat 11g . chol. 69mg .

sod. 36mg .fib 0g

LOW FAT PEACH FROZEN YOGURT

Preparation: 5 – 10 minutes, 30 – 50 minutes chilling time; optional 2 hours to “marinate” in freezer.

Makes eight 1/2-cup servings.

1 can (14 ounces) peaches packed in juice

2 cups lowfat vanilla yogurt

1/3 cup sugar

Drain peaches, reserving 1/2 cup of the juice. In a blender or food Processor fitted with the metal blade, pulse to chop the peaches.

Add the vanilla yogurt, sugar, and reserved peach juice. Process until smooth and the sugar is dissolved, about 1 minute. Turn the machine ON, pour peach/yogurt mixture into freezer bowl through ingredient spout and let mix until thickened, about 25 – 30 minutes.

Nutritional analysis per serving:

Calories 111 (6% from fat) .carbo. 24g .pro 3g . fat 1g . sat. fat 0g . chol.

5mg .sod. 39mg

LIME SHERBET

Preparation: 5 minutes, plus 30 –50 minutes chilling time; optional 2 hours to marinate.

Makes ten 1/2-cup servings.

3 cups whole milk

1 cup frozen limeade concentrate, thawed

3 tablespoons sugar

Drops green food coloring, optional

Combine the milk, limeade concentrate and sugar in a blender or food processor fitted with the metal blade. Add green food coloring if desired. Turn the machine ON, pour mixture into freezer bowl through ingredient spout and let mix until thickened, about 25 – 30 minutes.

Nutritional information per serving:

Calories 69 (31% from fat) .carbo. 10g .pro. 2g .fat 2g . sat. fat. . chol.

10mg .sod. 37mg

VARIATIONS:

Orange Sherbet: Combine 3 cups whole milk with 1-1/4 cups orange juice concentrate (thawed), and 2 tablespoons sugar in a blender or food processor until smooth. Freeze as directed.

Pineapple Sherbet: Combine 1 cup fat free vanilla yogurt, 2 cups whole milk, 1 cup pineapple juice concentrate (thawed), and 3 tablespoons sugar in a blender or food processor until smooth. Freeze as directed.

SLUSHIES

Preparation: 5 minutes or less; 15 – 20 minutes; plus 15 - 20 minutes chilling time. 4 cups cola or other soda, lemonade, cranberry juice, white grape juice, Kool-Aid., chilled .

Turn the machine ON, pour soda into freezer bowl and let mix until thick and slushy, about 15 to 20 minutes. Serve immediately, or if desired, transfer to an airtight container and store in the freezer. Remove from freezer at least 20 minutes before serving.

Do not use sugar free products to make slushies

Nutritional analysis per serving:

Calories 103 (0% from fat) .carbo. 27g .pro 0g . fat 0g . sat. fat 0g . chol.

0mg .sod. 5mg

CHOCOLATE FUDGESICLE ICE CREAM

Preparation: 5 minutes or less; 15 – 20 minutes; plus 15 - 20 minutes chilling time.

Makes ten 1/2-cup servings.

2 packages (3.4 – 3.9 ounce) instant chocolate pudding

3 cups reduced fat or lowfat milk, chilled

Place the ingredients in a medium mixing bowl and combine until well blended. Turn the machine ON, pour the mixture into freezer bowl, and let mix until mixture thickens, about 20 – 25 minutes. Serve immediately, or if desired, transfer to an airtight container and store in the freezer.

VARIATION:

Use your favorite flavor of instant pudding; white chocolate was a particular hit.

Nutritional analysis per serving (made with lowfat milk):

Calories 53 (15% from fat) .carbo. 9g .pro 3g . fat 1g .

sat. fat 0g . chol. 4mg .sod. 115mg

Nutritional analysis per serving (made with reduced fat milk):

Calories 59 (25% from fat) .carbo. 9g .pro 3g . fat 2g .

sat. fat 1g . chol. 6mg .sod. 113mg

THICK AND FROSTY PINA COLADAS

Preparation: 5 minutes or less; 15 – 20 minutes; plus 15 - 20 minutes chilling time.

Makes twelve 1/2-cup servings.

3 cups whole milk

1 can (10-ounce) frozen pi.a colada concentrate, thawed 1 teaspoon rum extract Combine the milk, pi.a colada concentrate, and rum extract in a blender or food processor fitted with the metal blade. Process to combine about 15 seconds. Turn the machine ON, pour into freezer bowl through ingredient spout and let mix until mixture becomes slushy, about 20 – 25 minutes. Serve immediately for frozen drinks.

Nutritional information per serving:

Calories 115 (76% from fat) .carbo. 4g .pro. 3g .fat 10g . sat. fat 8g . chol.

8mg

sod. 34mg

IMPORTANT NOTICES

When using an electrical appliance, basic safety precautions should always be followed to reduce the risk of fire, electric shock, and/or injury, including the following:

1. Read all instructions before using.
2. Ensure the voltage is compliant with the voltage range stated on the rating label, and ensure the earthing of the socket is in good condition.
3. If the supply cord is damaged, it must be replaced by the manufacturer or its service agent or authorized dealer.
4. Do not upend this product or incline it over a 45 degree angle.
5. To protect against risk of electric shock, do not pour water on cord, plug and ventilation, immerse the appliance in water or any other liquid.
6. Unplug the appliance after using or before cleaning.
7. Keep the appliance 3 inches from other objects to ensure proper ventilation.
8. Do not use accessories that are not recommended by manufacturer.
9. This appliance is not intended for use by persons (including children) with reduced physical, sensory or mental capabilities, or lack of experience and knowledge, unless they have been given supervision or instruction concerning use of the appliance by a person responsible for their safety. Children should be supervised to ensure that they do not play with the appliance.
10. Do not use the appliance close by flames, hot plates or stoves.
11. Do not switch on the power button frequently (ensure 5min. interval at least) to avoid damage to the compressor.
12. To avoid fire and short circuiting, do not insert metal sheet or other electrical objects into the appliance.
13. To avoid damage to the barrel, when taking out the ice cream, do not knock the barrel or edge of barrel.
14. Do not switch on the power before installing the removable bowl or mixing blade.
15. The initial temperature of the ingredients is $77\pm 10^{\circ}\text{F}$. Do not put the ingredients into freezer for pre-freeze, as it will easily make the mixing blade blocked before the ice cream is in good condition.
16. Please do not remove the blender motor while making ice cream.
17. Do not use outdoors.
18. Never clean with scouring powders or hard implements.
19. Please keep the instruction manual.

Specifications

Description of product	Ice Cream Maker
Model	ICM301SS
Voltage/Frequency	AC 110-120V~60Hz
Rated Current	2.0A
Color	Stainless Steel / Black
Refrigerant	R134a, 2.31oz
Dimensions (Width x Depth x Height)	15 3/16"x11 9/16"x12 5/16"
Weight	24.7 lbs

Note: Technical data and performance information provided for reference only.

Specifications are subject to change. Check the rating label on the ice maker for the most accurate information.

Limited Warranty

One (1) Year Parts & Ninety (90) Days Labor

This product is warranted by EdgeStar to be free from defective workmanship and materials, subject to any conditions set forth as follows:

WHAT IS COVERED:

LABOR: For a period of NINETY (90) DAYS from the date of original purchase, labor will be performed free of charge at an authorized EdgeStar repair facility. At its option, EdgeStar will repair the product with new or remanufactured parts, or exchange the defective product with a new, refurbished, or remanufactured product. If a product is replaced, it will carry the remaining warranty of the original product. After the ninety (90) day period, EdgeStar will no longer be responsible for labor charges incurred. All defective products and parts covered by this warranty will be repaired or replaced on a mail-in basis to an EdgeStar authorized repair facility.

PARTS: For a period of ONE (1) YEAR from the date of original purchase, EdgeStar will supply new, rebuilt, or refurbished parts free of charge. EdgeStar may request a defective part be returned in exchange for the replacement part. All replacement parts or products will be new, remanufactured, or refurbished. All products and parts replaced by EdgeStar under warranty service become the property of EdgeStar.

This warranty applies to the original purchaser only, and only covers defects in workmanship experienced during operation of the product under normal service, maintenance, and usage conditions. This warranty applies to the purchase and use of this product in residential settings within the United States of America.

WHAT IS NOT COVERED:

The following limitations apply to the coverage of this warranty. This warranty does not cover:

- Labor charges for installation, setup or training to use the product.
- Shipping damage, and any damage caused by improper packaging for shipment to an authorized service center, and any damaged caused by improper voltage or any other misuse, including abnormal service, handling, or usage.
- Cosmetic damage such as scratches and dents.
- Normal wear and tear on parts or replacement of parts designed to be replaced, e.g. filters, cartridges, batteries.
- Service trips to deliver, pick-up, or repair, install the product, or to instruct in proper usage of the product.
- Damages or operating problems resulting from misuse, abuse, operation outside environmental specifications, uses contrary to instructions provided in the owner's manual, accidents, acts of God, vermin, fire, flood, improper installation, unauthorized service, maintenance negligence, unauthorized installation or modification, or commercial use.
- Labor charges incurred 91 days or more after the date of original purchase.
- The use of EdgeStar products in commercial settings.
- Optional accessories, attachments, and appearance items.
- Products that have been modified to perform outside of specifications without the prior written permission of EdgeStar.
- Products lost in shipment, or theft.
- Products sold AS IS or from an unauthorized reseller.
- Products that have had their serial numbers removed or defaced. Products with serial numbers that have been invalidated.

OBTAINING WARRANTY SERVICE:

If you believe your product is defective, contact EdgeStar Customer Support for troubleshooting assistance and warranty service at 1-866-319-5473. Please have your serial number and proof of purchase available. Once an EdgeStar authorized representative has confirmed that your product is defective and eligible for warranty service, the product must be returned to an EdgeStar repair facility. The purchaser is solely responsible for prepaying all shipping related costs to and from the repair facility. EdgeStar is not responsible for damage resulting from shipper mishandling or improper packaging. Do not return a defective product to the place of purchase. Products received without a return authorization number will be refused.

THIS WARRANTY IS IN LIEU OF ANY OTHER WARRANTY, EXPRESSED OR IMPLIED, INCLUDING WITHOUT LIMITATION, ANY WARRANTY OF MERCHANTABILITY OR FITNESS FOR A PARTICULAR PURPOSE. TO THE EXTENT ANY IMPLIED WARRANTY IS REQUIRED BY LAW, IT IS LIMITED IN DURATION TO THE EXPRESS WARRANTY PERIOD ABOVE. NEITHER THE MANUFACTURER NOR ITS DISTRIBUTORS SHALL BE LIABLE FOR ANY INCIDENTAL, CONSEQUENTIAL, INDIRECT, SPECIAL, OR PUNITIVE DAMAGES OF ANY NATURE, INCLUDING WITHOUT LIMITATION, LOST REVENUES OR PROFITS, OR ANY OTHER DAMAGE WHETHER BASED IN CONTRACT, TORT, OR OTHERWISE. SOME STATES DO NOT ALLOW THE EXCLUSION OF INCIDENTAL OR CONSEQUENTIAL DAMAGES, SO THE ABOVE EXCLUSION MAY NOT APPLY TO YOU. THIS WARRANTY GIVES YOU SPECIFIC LEGAL RIGHTS. YOU MAY HAVE OTHER RIGHTS THAT VARY FROM STATE TO STATE.



EdgeStar Products
500 N. Capital of TX Hwy, Bldg 5
Austin, TX 78746

Toll Free: 1-866-319-5473
Web: <http://www.edgestar.com>
E-mail: service@edgestar.com

Register your product, download owner's manuals, access additional troubleshooting resources, and obtain more information on other great EdgeStar products on the web at: **<http://www.edgestar.com>**

Product contents and specifications may change without notice.

Copyright © 2011 Living Direct, Inc. All rights reserved.