

EDGESTAR

Tower Heater

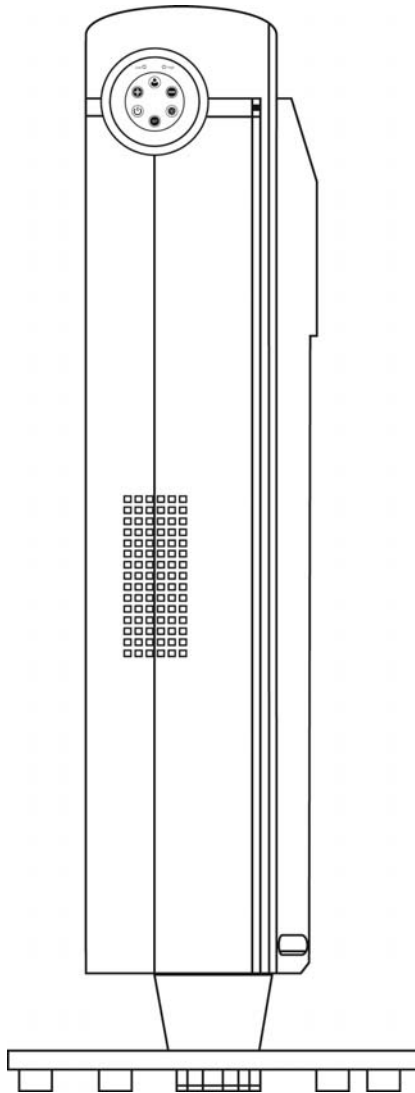

HT200BL

Owner's Manual

For more information on other great Edgestar products on the web, go to <http://www.edgestar.com>

Important Safety Information

Improper handling can cause serious damage to the appliance and/or to the user. Please read the following safety information.



Electrical Safety

- Do not exceed the power outlet ratings.
- This requires the standard electrical supply (115 V, 60Hz), that is properly grounded in accordance with the National Electrical Code and local codes and ordinances is required.
- Use outlets that cannot be turned off by a switch or pull chain.
- Do not operate the unit with a power plug missing the ground plug, a damaged cord or a loose socket.
- Never plug or unplug the unit with wet hands.
- Do not bypass, cut or remove the grounding plug.
- Do not use extension cords or power strips with this unit. You may need to contact your electrician if it is necessary to use a longer cord or if you do not have a grounded outlet. Do not modify the power cord's length or share the outlet with other appliances.
- Do not start or stop the unit by switching the circuit's power on and off.
- This product is designed for indoor use only.
- Keep the unit and control panel dry; do not spray water directly on the control panel to avoid electric shock.
- Do not touch the power plug with hands.
- Do not let the power cord touch the front panel as it could cause damage to the insulation of the wires.
- Always turn the unit off and disconnect it from the outlet when cleaning.
- Disconnect the plug if it is not going to be used for a long period of time.
- If the power cord is damaged, it must be replaced by the manufacturer, a service agent, or a qualified technician.
- Read the rating label on the product for power requirements.
- Use only the correct power supply with appropriate amperage.



General Safety

- This appliance is not intended for use by persons, including children, with reduced physical, sensory or mental capabilities, unless they have been given supervision or instruction concerning the use of the appliance by the person(s) responsible for their safety.
- Children should be supervised to ensure that they do not play with the controls or drop any objects into the air outlets or vents.
- This unit is designed to be installed indoors, and protected from rain, sleet, snow, and/or moisture.
- Do not place objects or let any person sit on top of the unit.
- Do not shake the unit when it is in operation.
- Do not use the unit in direct sunlight.
- Operate this heater only in its upright position.
- Never locate heater where it may come in contact with water such as a laundry room or bathroom.
- Do not use the heater in areas where gasoline, paint or flammable liquids are used or stored.
- Keep combustible materials such as furniture, pillows, bedding, papers, clothes, and curtains away from the front and rear of the unit.
- Only use the unit in the upright position on a flat, level surface.
- Route the power cord carefully to avoid a tripping hazard.
- When unit is in use, keep hands away from front panel as the unit will get hot.
- Do not remove any part of the casing unless instructed by an authorized technician.
- You should never attempt to repair the unit yourself.
- Contact customer service for service options if the unit needs service.
- Do not pull the unit by the cord.
- Immediately unplug the unit if it makes strange sounds, emits smells or smoke comes out of it, and contact customer service.

Electrical products should not be disposed of with household waste. Please contact your local recycling center for more information on how to recycle electronic waste.



Table of Contents

IMPORTANT SAFETY INFORMATION	I
INTRODUCTION	1
PARTS IDENTIFICATION	2
BEFORE YOU BEGIN	3
<i>Unpacking the Tower Heater</i>	3
<i>Assembly</i>	3
OPERATING INSTRUCTIONS	4
CONTROL PANEL/ REMOTE CONTROL OPERATION	4
CLEANING AND MAINTENANCE	6
PREPERATION FOR STORAGE	6
TROUBLESHOOTING	7
SPECIFICATIONS	8
EDGE STAR LIMITED WARRANTY	9

This owner’s manual is provided for reference use only. Specifications may change without prior notice. Refer to the product label on the back of your product for the latest technical information.

Introduction

Thank you for purchasing this EdgeStar tower heater. We are glad you chose us. We believe that your purchase of this product opens a relationship between you and EdgeStar. We will provide the customer support needed to nurture that relationship.

This manual contains important information regarding the proper installation, usage and maintenance of your tower heater. Following this manual will ensure that your product will work at its peak performance and efficiency.

Please save the original product packaging in case you need to safely transport your tower heater.

For Your Records:

Please write down the model number and serial number below for future reference. Both numbers are located on the ratings label on the back of your unit and are needed to obtain warranty service. You may also want to staple your receipt to this manual as it is the proof of your purchase, and is also needed for service under your warranty.

Model Number: _____

Serial Number: _____

Date of Purchase: _____

To better serve you, please do the following before contacting customer service:

- If you received a damaged product, immediately contact the dealer that sold you the product.
- Read and follow this instruction manual carefully to help you install, use and maintain your tower heater.
- Read the troubleshooting section of this manual as it will help you diagnose and solve common issues.
- Visit us on the web at <http://www.edgestar.com> to register your product, download product guides, additional troubleshooting resources and up-to-date information.
- If you need warranty service, our friendly customer service representatives are available via email at service@edgestar.com or by telephone at **1 (866) 319-5473**.

Parts Identification

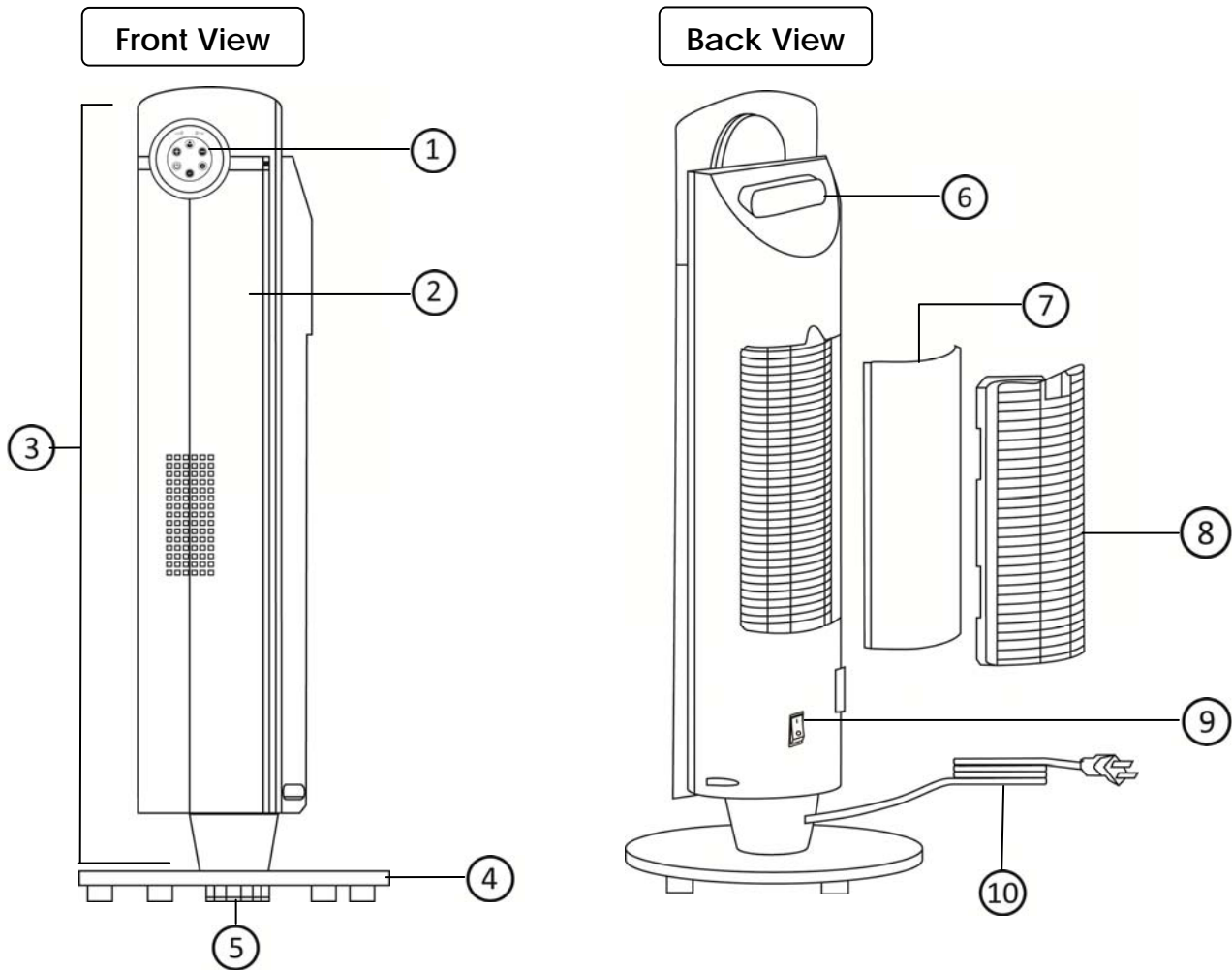

1	Control Panel	6	Handle
2	Front Grill	7	Filter
3	Stand Column	8	Back Grill
4	Base	9	Power Switch
5	Base Attachment Nut	10	Power Cord



IMPORTANT: Do not remove any safety, warning, or product information labels from your ice maker.

Before you Begin

Unpacking the Tower Heater

Carefully remove the packaging materials. Remove any shipping tape and glue from your tower heater before using. Do not use sharp instruments, rubbing alcohol, flammable fluids, or abrasive cleaners to remove tape or glue. These products can damage the surface of your heater. Check to make sure the base, remote, and base attachment nut is included with the heater. If any parts are missing, please contact our customer service.

Assembly

Insert the bottom end of the stand column into the center hole of the base. Screw on the base attachment nut to fasten the base to the column.

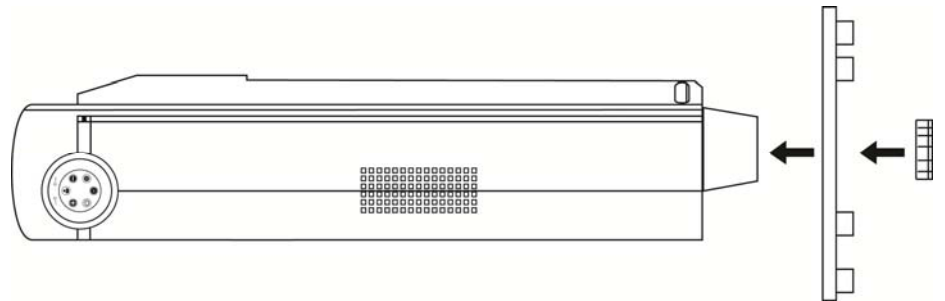

Locate the tower heater on a level and flat surface away from direct sunlight. Make sure unit is away from contact of fabrics such as curtains, furniture, etc. The appliance must be positioned so that the power plug is accessible.

Operating Instructions

After connecting the tower heater power plug to an outlet, the unit will be ready to operate.

Control Panel/ Remote Control Operation

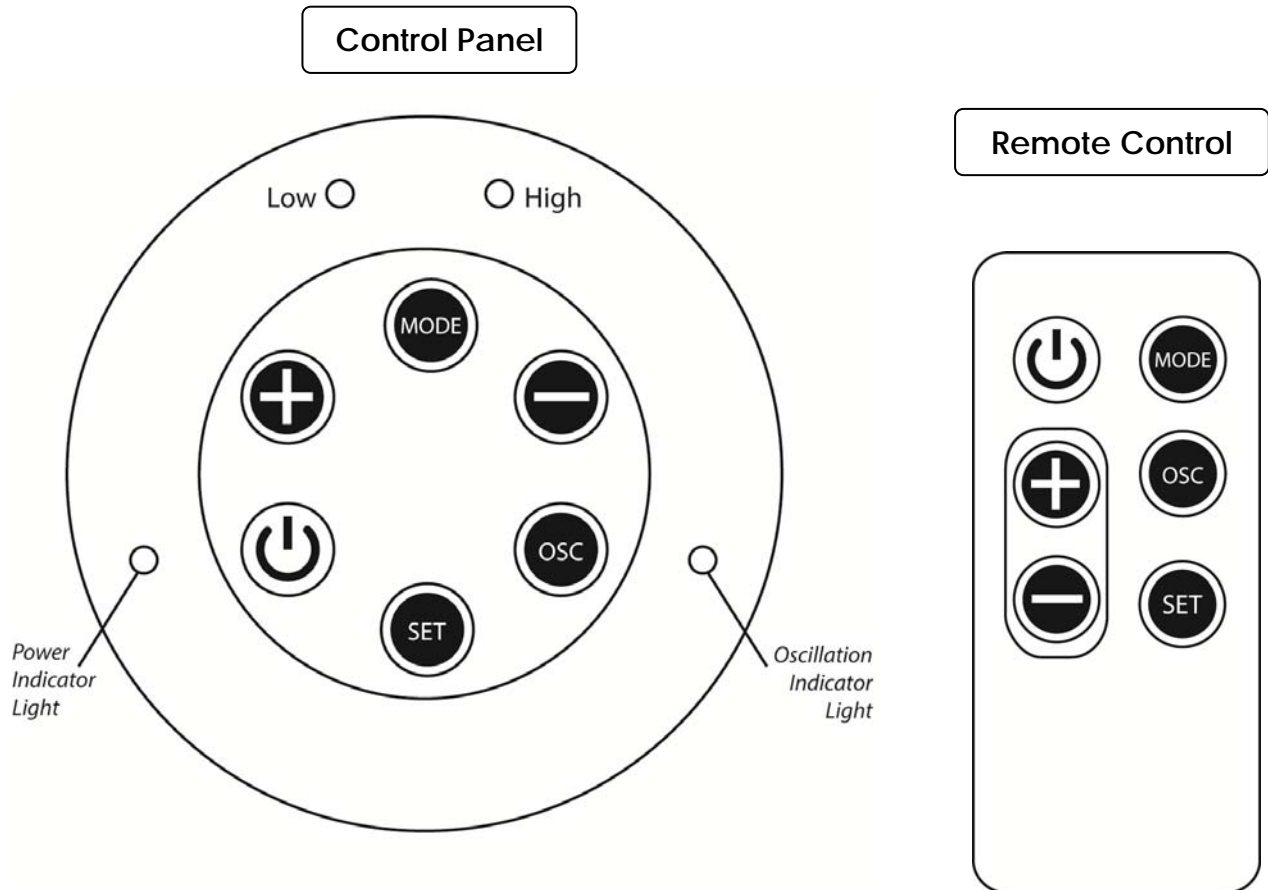

POWER



To power the unit on there is a switch at the back of the unit, make sure it is on the "I" position.

Press the "power" button, the control panel and power indicating light will illuminate which will let you know the unit is on. The heater will automatically start operation on the low setting.

Press the power button again to turn unit off. All functions will stop and the unit goes into the standby mode and the power indicating light will turn off.

MODE



The unit will automatically be set to the low setting when powered on. To turn the setting to high press the "mode" button once and the high indicator light will illuminate. To turn back to low setting press the "mode" button again and the low indicator light will illuminate.

OSCILLATION



When the heater is in operation press the "Osc" to turn on the oscillation feature. The body of the unit will swing left and right automatically, at the same time the oscillation indicator light will illuminate. Press the "Osc" once more to turn oscillation off.

SET



The "set" button allows you to set the temperature and/or time.

To set the timer press the "set" button once. The LED display will show "0 H", press the "+" or "-" until you have reach the desired time you want the unit to shut off. The timer range is from 1-12 hours and is in increments of 1 hour.



To set the temperature press the "set" button again. The LED display panel will reflect 77°F and you can now adjust the temperature using the "+" or "-" until you reach desired temperature. The temperature range is from 59°F to 99°F. The temperature will increase/decrease in 1°F and reflect your set temperature. After 5 seconds the LED display panel will reflect the current room temperature.



When the room temperature is below 14°F the LED display panel will show as "LO", and when the temperature is above 99°F the display panel will show as "HI". When the temperature is between 14°F to 99°F the LED display panel will show the actual room temperature.

Note:

If you do not wish to set the timer but only change the temperature press the "set" button twice to bypass the set timer function.

Tip Over Switch

This heater is fitted with a safety tip-over switch to ensure it can only be operated in the correct upright position. When the unit tilts more than 45° you will hear a click and the heater will cut off automatically.

Cleaning and Maintenance

Clean the heater and filter regularly to maximize performance and efficiency, and help to prolong the unit's life. Be sure to always unplug the heater from the power outlet before cleaning.

Use a soft dry cloth to wipe the body clean. If necessary, use lukewarm water to dampen a cloth to clean the unit with mild detergent.

Never use abrasive chemicals, volatile substances, gasoline, detergents, chemically treated cloths, or other cleaning solvents that may damage the exterior.

Never spray water directly on the unit.

Depending on environmental conditions, the filter may require cleaning as frequent as every month. If too much dust accumulates in the filter it will affect the performance. To clean the filter take the back grill cover off from the back of the unit. Remove filter and place directly in water for a few minutes, a mild detergent can be added to the water. Gently clean the filter and place on towel to dry. Make sure the filter is completely dry before placing back into the heater and reinstall back grill cover.

Preparation for Storage

If you are not going to be using the unit for an extended period of time, follow the instructions below before storing your unit:

1. Power off the unit and unplug it.
2. Clean the heater and filter.
3. Carefully wind the power cord.
4. Store in a dry location.

Troubleshooting

Follow the troubleshooting guide below to resolve common issues.

Issue	Possible Cause	Solution
Heater will not start up		Check if power switch on the back of the unit is on the "I" position. Check if power plug is inserted well. Check to make sure the electrical outlet has power.
The functions on display panel do not work	The unit is probably in Standby mode.	In standby mode only the power button works. Press the power button and then press the function on the display panel.
Heater makes a sound when moved		There is a steel ball located inside of the unit for the tip-over protection function. This is a normal sound and will only be heard when moved. If the sound differs from the one described or unit makes a sound when standing still please call an authorized technician.
Heater automatically turns off while in operation	Room temperature is equal to default temperature.	If the heater detects the current room temperature is 77° F it will automatically shut off. The default setting is 77° F, if you wish to heat to a higher temperature adjust the temperature setting to be higher than the current room temperature.
The unit does not start when place on its side or tilted.		The heater can only be operated standing upright on a solid level floor. The unit has tip-over protection function and power will automatically cut off when tilted or on its side.

Specifications

Description of product	Tower Heater
Model	HT200BL
Voltage/Frequency	120V, 60Hz
Input Power	Low: 750W / High: 1500W
Timer	1-12 Hr
Color	Black
Dimensions WxDxH	9 1/16" x 9 1/16" x 27 1/16"
Weight	8.2 lbs

EdgeStar Limited Warranty

One (1) Year Parts & Ninety (90) Days Labor

This product is warranted by EdgeStar to be free from defective workmanship and materials, subject to any conditions set forth as follows:

WHAT IS COVERED:

LABOR: For a period of NINETY (90) DAYS from the date of original purchase, labor will be performed free of charge at an authorized EdgeStar repair facility. At its option, EdgeStar will repair the product with new or remanufactured parts, or exchange the defective product with a new, refurbished, or remanufactured product. If a product is replaced, it will carry the remaining warranty of the original product. After the ninety (90) day period, EdgeStar will no longer be responsible for labor charges incurred. All defective products and parts covered by this warranty will be repaired or replaced on a mail-in basis to an EdgeStar authorized repair facility.

PARTS: For a period of ONE (1) YEAR from the date of original purchase, EdgeStar will supply new, rebuilt, or refurbished parts free of charge. EdgeStar may request a defective part be returned in exchange for the replacement part. All replacement parts or products will be new, remanufactured, or refurbished. All products and parts replaced by EdgeStar under warranty service become the property of EdgeStar.

This warranty applies to the original purchaser only, and only covers defects in workmanship experienced during operation of the product under normal service, maintenance, and usage conditions. This warranty applies to the purchase and use of this product in residential settings within the United States of America.

WHAT IS NOT COVERED:

The following limitations apply to the coverage of this warranty. This warranty does not cover:

- Labor charges for installation, setup or training to use the product.
- Shipping damage, and any damage caused by improper packaging for shipment to an authorized service center, and any damaged caused by improper voltage or any other misuse, including abnormal service, handling, or usage.
- Cosmetic damage such as scratches and dents.
- Normal wear and tear on parts or replacement of parts designed to be replaced, e.g. filters, cartridges, batteries.
- Service trips to deliver, pick-up, or repair, install the product, or to instruct in proper usage of the product.
- Damages or operating problems resulting from misuse, abuse, operation outside environmental specifications, uses contrary to instructions provided in the owner's manual, accidents, acts of God, vermin, fire, flood, improper installation, unauthorized service, maintenance negligence, unauthorized installation or modification, or commercial use.
- Labor charges incurred 91 days or more after the date of original purchase.
- The use of EdgeStar products in commercial settings.
- Optional accessories, attachments, and appearance items.
- Products that have been modified to perform outside of specifications without the prior written permission of EdgeStar.
- Products lost in shipment, or theft.
- Products sold AS IS or from an unauthorized reseller.
- Products that have had their serial numbers removed or defaced. Products with serial numbers that have been invalidated.

OBTAINING WARRANTY SERVICE:

If you believe your product is defective, contact EdgeStar Customer Support for troubleshooting assistance and warranty service at 1-866-319-5473. Please have your serial number and proof of purchase available. Once an EdgeStar authorized representative has confirmed that your product is defective and eligible for warranty service, the product must be returned to an EdgeStar repair facility. The purchaser is solely responsible for prepaying all shipping related costs to and from the repair facility. EdgeStar is not responsible for damage resulting from shipper mishandling or improper packaging. Do not return a defective product to the place of purchase. Products received without a return authorization number will be refused.

THIS WARRANTY IS IN LIEU OF ANY OTHER WARRANTY, EXPRESSED OR IMPLIED, INCLUDING WITHOUT LIMITATION, ANY WARRANTY OF MERCHANTABILITY OR FITNESS FOR A PARTICULAR PURPOSE. TO THE EXTENT ANY IMPLIED WARRANTY IS REQUIRED BY LAW, IT IS LIMITED IN DURATION TO THE EXPRESS WARRANTY PERIOD ABOVE. NEITHER THE MANUFACTURER NOR ITS DISTRIBUTORS SHALL BE LIABLE FOR ANY INCIDENTAL, CONSEQUENTIAL, INDIRECT, SPECIAL, OR PUNITIVE DAMAGES OF ANY NATURE, INCLUDING WITHOUT LIMITATION, LOST REVENUES OR PROFITS, OR ANY OTHER DAMAGE WHETHER BASED IN CONTRACT, TORT, OR OTHERWISE. SOME STATES DO NOT ALLOW THE EXCLUSION OF INCIDENTAL OR CONSEQUENTIAL DAMAGES, SO THE ABOVE EXCLUSION MAY NOT APPLY TO YOU. THIS WARRANTY GIVES YOU SPECIFIC LEGAL RIGHTS. YOU MAY HAVE OTHER RIGHTS THAT VARY FROM STATE TO STATE.



EdgeStar Products
500 N. Capital of TX Hwy, Bldg 5
Austin, TX 78746

Toll Free: 1-866-319-5473
Web: <http://www.edgestar.com>
E-mail: service@edgestar.com

Register your product, download owner's manuals, access additional troubleshooting resources, and obtain more information on other great EdgeStar products on the web at: **<http://www.edgestar.com>**

Product contents and specifications may change without notice.

Copyright © 2011 Living Direct, Inc. All rights reserved.