

## BIDW1802 Service Manual

### 18" Built-In Dishwasher



BIDW1802BL / BIDW1802SS / BIDW1802WH

**CAUTION:** Read all safety precautions in the manual before servicing the unit

# Table of Contents

SAFETY PRECAUTIONS .....	2
General Safety .....	2
Electrical Safety.....	3
Component Location View .....	4
Front View .....	4
Top View .....	4
Interior View .....	5
Detergent / Rinse Aide Compartment View .....	5
Interior View of Basin .....	6
Left Side View .....	6
Bottom View .....	7
PCB Connection Locator View .....	8
Dishwasher Components .....	9
Outer Door.....	9
Control Panel.....	9
Door Switch Assembly .....	11
Detergent / Rinse Aid Module.....	12
Inner Door Panel .....	14
Door Bottom Seal .....	15
Tub Gasket and Trim.....	15
Air Breaker Assembly.....	16
Nozzle Duct.....	17
PCB.....	17
Water Inlet Valve .....	18
Pressure Switch .....	19
Drain Pump Assembly.....	21
Thermistor .....	21
Turbidity Sensor .....	22
Heating Element.....	23
Wash Pump Assembly .....	24
Sump Assembly .....	26
Sump.....	27
Troubleshooting .....	28
Factory Diagnostic Mode.....	28
Error Codes .....	29
Exploded Views and Parts List.....	30
Wiring Diagram .....	37

## **SAFETY PRECAUTIONS**

**WARNING:** This manual and the information contained herein is intended for use by certified technicians. The manufacturer or seller is not responsible for the interpretation or misuse of the information provided, nor does it assume any liability in connection with its use.

**The safeguards and warnings indicated in this manual do not cover all possible conditions which may occur. Common sense, caution, and care must be exercised.**

- To prevent electric shock, always unplug an appliance from the power supply before attempting any service.
- Disconnect the power cord by grasping the plug, not the cord.
- Do not bypass, cut, or remove the grounding plug.
- Prevent water from spilling onto electric elements or the machine parts.
- Always refer to the rating label on the appliance for rated current and voltage.
- Always check line voltage and amperage.
- Always use exact replacement parts.
- Any attempt to repair a major appliance may result in personal injury and property damage.

### ***General Safety***

- Always unplug an appliance from the power supply before attempting any service. Disconnect the power cord by grasping the plug, not the cord.
- Do not allow children or pets to play on or in the appliance.
- This machine is not intended for use by persons (including children) with reduced physical, sensory or mental capabilities, or lack of experience and knowledge, unless they have been given supervision or instruction concerning use of the machine by a person responsible for their safety.
- Do not install or store this appliance where it will be exposed to the weather.
- Disconnect from the power socket before cleaning or maintenance.
- If the plug (power cord) is damaged, it must be replaced by the manufacturer or an authorized service representative.
- This machine shall be repaired only by an authorized service representative. Only genuine replacement parts should be used.
- If connected to a circuit protected by fuses, use time-delay fuses with this appliance.
- Do not lean items against the door.
- Please do not close the door with excessive force. If it is found difficult to close the door, please check for obstruction.
- When you plan to dispose of this unit in the future, please comply with the local waste disposal regulations. Remove any doors so that children and pets will not be trapped in the unit.

## **Electrical Safety**

- Do not exceed the power outlet ratings.
- It is recommended that the unit be connected to its own circuit.
- A standard electrical supply that is properly grounded in accordance with the National Electrical Code and all state and local codes and ordinances is required.
- Do not use outlets that can be turned off by a switch or pull chain.
- Always turn the unit off and unplug it from the outlet when cleaning.
- Unplug the unit if it is not going to be used for an extended period of time.
- Do not operate the unit with a power plug missing the ground plug, a damaged cord, or a loose socket.
- Be sure the appliance is properly grounded.
- Do not bypass, cut, or remove the grounding plug.
- If the power cord is damaged, it must be replaced by the manufacturer or a qualified technician.
- Do not use extension cords or power strips with this unit. You may need to contact an electrician if it is necessary to use a longer cord or if you do not have a properly grounded outlet. Do not modify the power cord's length or share the outlet with other appliances.
- Do not start or stop the unit by switching the electrical circuit's power on and off.
- Immediately unplug the unit if it makes strange sounds, emits an odor or smoke and contact customer service.
- Do not remove any part of the casing unless instructed by an authorized technician.
- Before the appliance is removed from service or discarded, remove any doors and cut off the power cord.

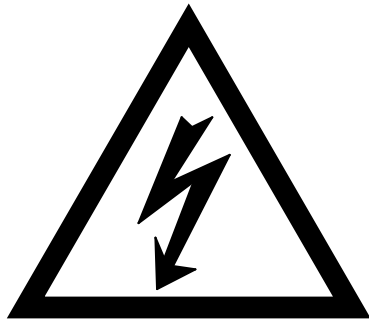

**Component Location View**

***Front View***

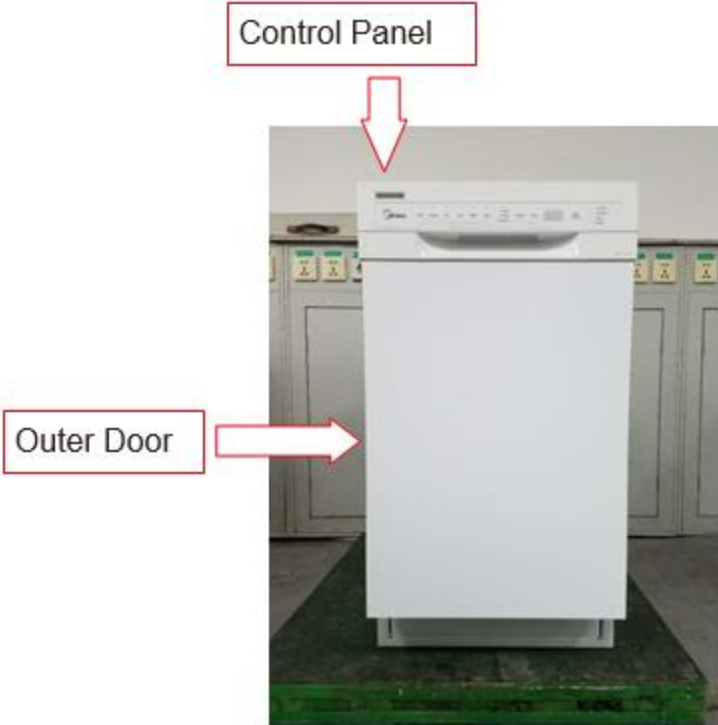

***Top View***

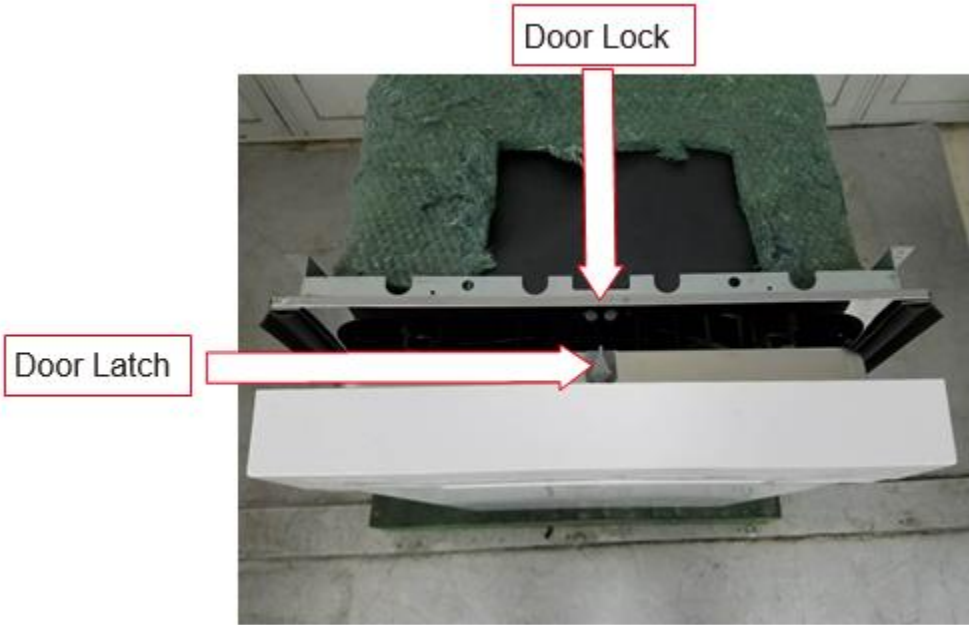

***Interior View***



***Detergent / Rinse Aide Compartment View***

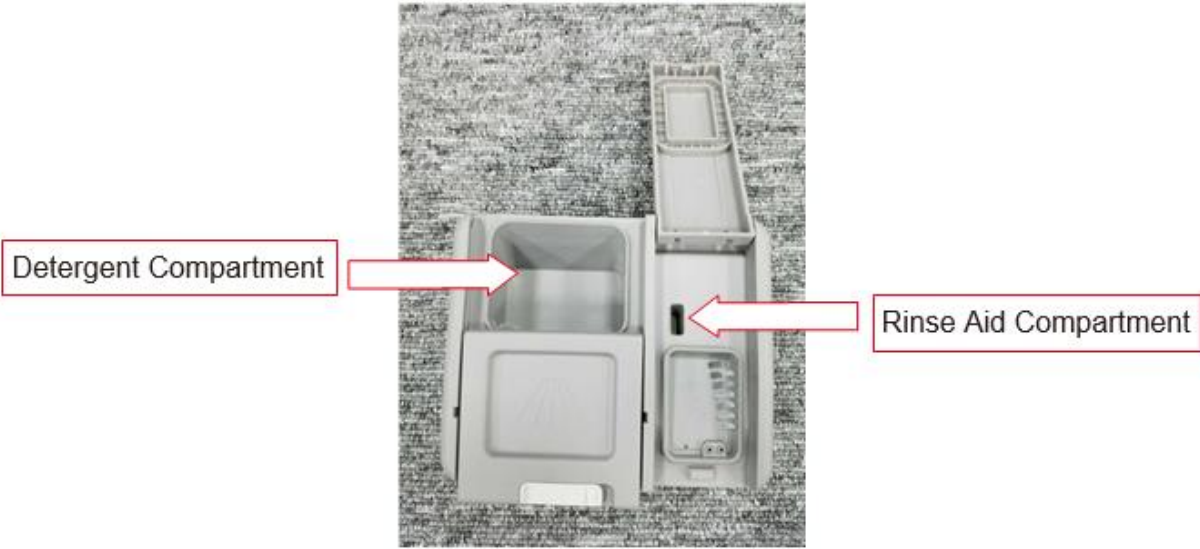

**Interior View of Basin**



**Left Side View**



**Bottom View**

Note: Drain hose shown is shipping configuration

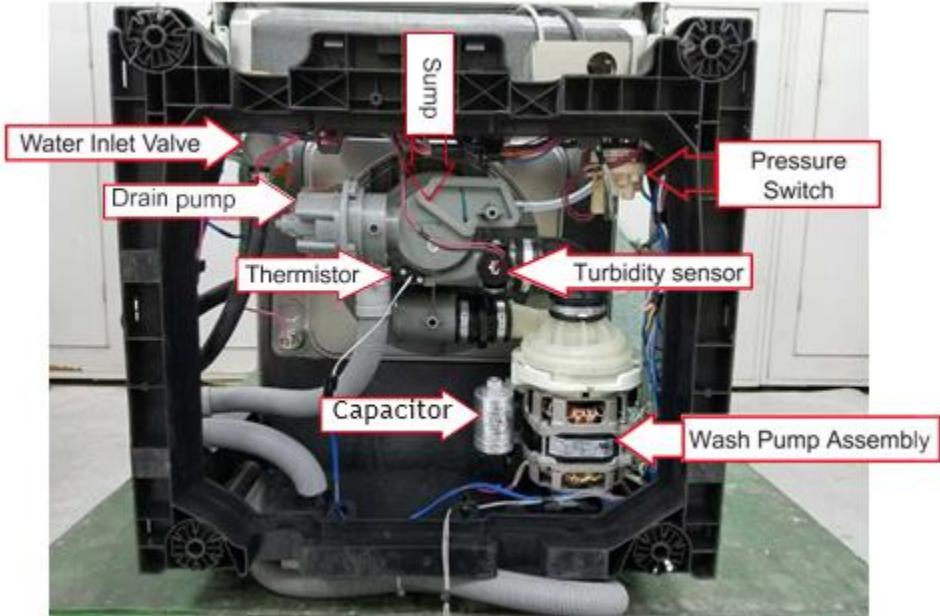



# PCB Connection Locator View

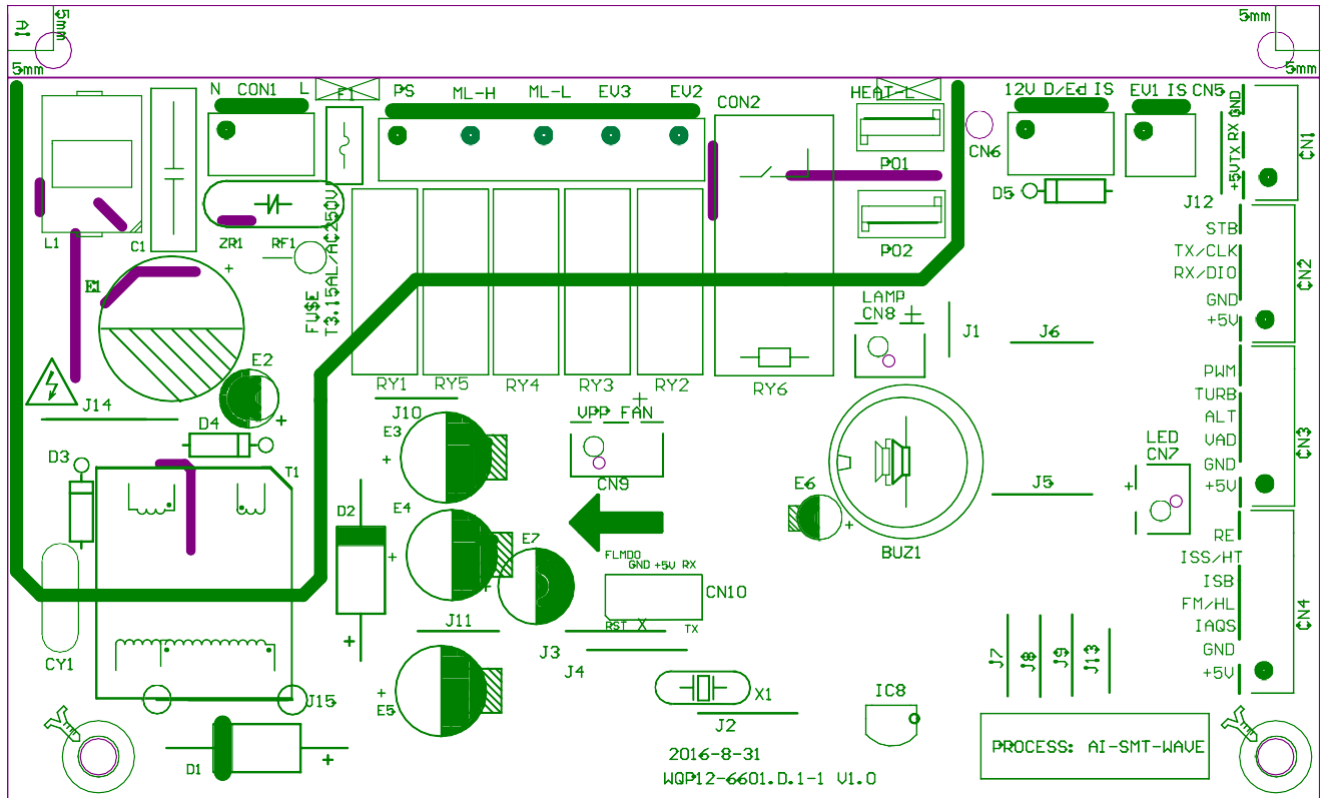

CON1 L-N

CON2 120V AC output

Pin1=Drain pump

Pin2=High speed – Wash Pump

Pin3=Low speed – Wash Pump

Pin4=Not used

Pin5=Not used

PO1 PO2 Heater

VPP Fan – Not used

CN1 Not used

CN2 Connector to display board

CN3 Turbidity sensor

CN4 Flow meter / leak detector

CN5 Water valve and door switch

CN6 Dispenser and door switch

CN7 Not used

CN8 Not used

## Dishwasher Components

### ***Outer Door***

The outer door panel covers the inner door to the dishwasher and must be removed to access the detergent/rinse module and bottom door seal.

To remove the outer door panel, first remove the 6 screws, and then separate the panel from the inner door.



### ***Control Panel***

The control panel consists of the PCB user interface board. To remove the control panel:

1. Disconnect the power supply to the dishwasher.
2. Remove the 8 screws.





3. Disconnect the signal line and remove the handle cover
4. Remove the 4 screws

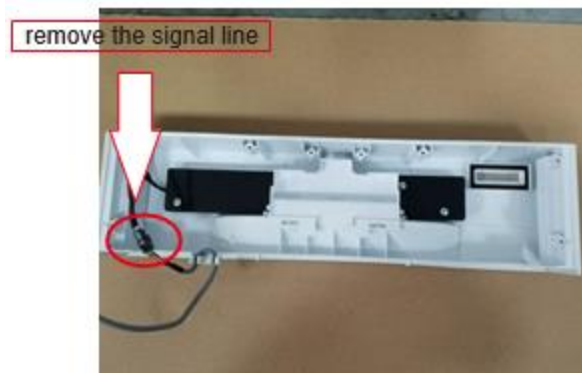

## 5. Remove the PCB user interface board

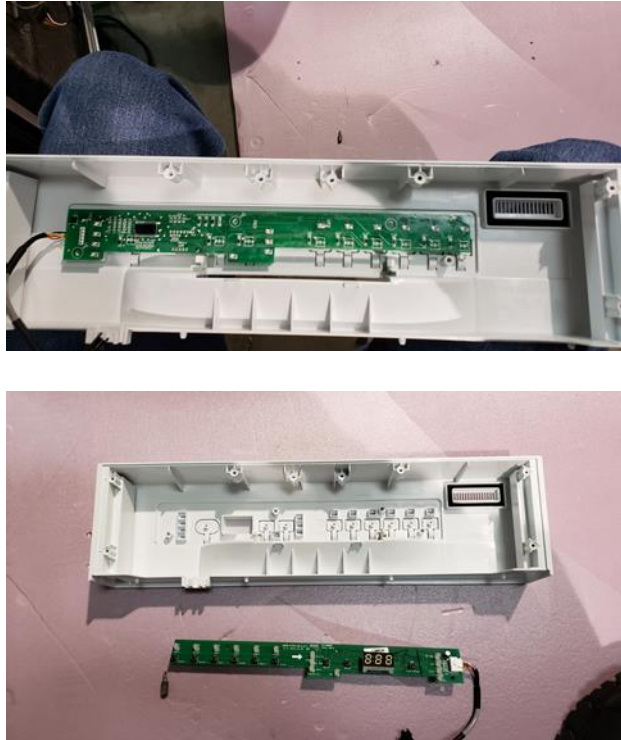

### ***Door Switch Assembly***

The door switch assembly consists of the door lock and door latch. The door lock is connected to the line (hot) side of 12 VAC.

**WARNING:** Power remains applied to the controller location at CN6, Pin 1. while the door is open (unlatched).

To remove the door switch assembly:

- Disconnect the power supply to the dishwasher.
- Disconnect the 2 wiring harnesses from the door switch.



- Remove the 2 screws



### ***Detergent / Rinse Aid Module***

The outer door must be removed to access the detergent / rinse aid module. (See Outer Door.) The detergent/rinse module is connected by 4 wires and held in place by 10 snap joints. The detergent/rinse module operates on 12 VAC.

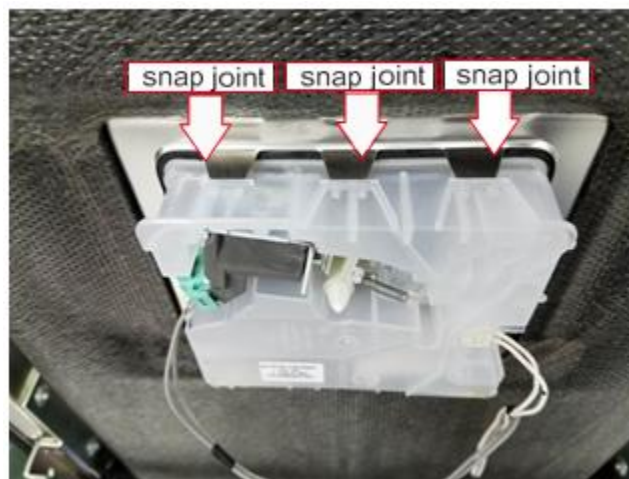

The detergent/rinse module automatically dispenses both the detergent and the rinse aid at the appropriate times. The module is activated five times during a wash cycle. Detergent is dispensed at the beginning of the main wash cycle for one time and rinse aid at the beginning of the final rinse for four times. To remove and install the detergent/rinse module:

1. Remove the 2 wiring harnesses
2. Use a flat-head screwdriver to release the snap joints and then pull in to remove the module.

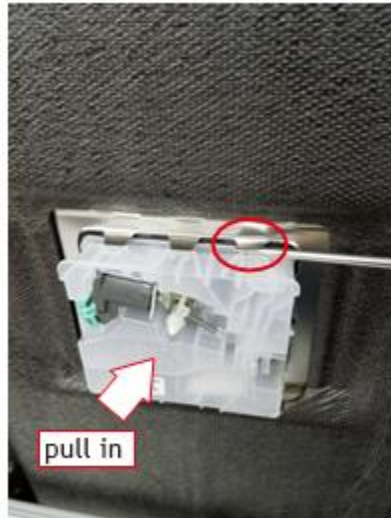

3. To install the new module press inward until it snaps into place.



4. Reconnect the 2 wiring harnesses



## ***Inner Door Panel***

To remove the inner door panel:

1. Disconnect power.
2. Remove the control panel. (See Control Panel.)
3. Remove the detergent/rinse module. (See Detergent / Rinse Aid Module.)
4. Remove the 2 screws from the hinge panel.
5. Remove the 2 screws from each of the base side panels.



6. Disconnect door spring and door cable.
7. Open the inner door approximately 10 degrees and lift the door until the door hinge separates from the pin. A flat-head screwdriver may be used to assist.

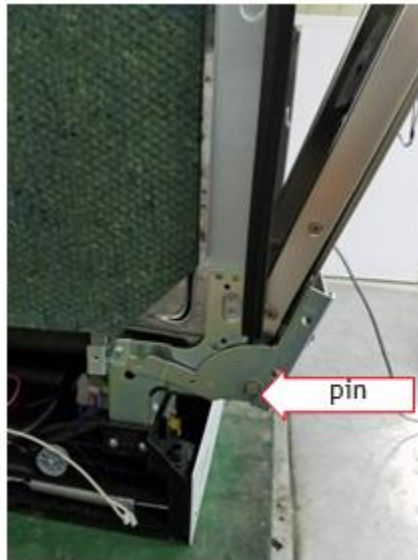

### ***Door Bottom Seal***

The door bottom seal prevents water leakage by sealing the bottom of the door to the tub. It cannot be replaced as a separate part on this dishwasher. It must be replaced as part of the inner door panel. (See Inner Door Panel.)

### ***Tub Gasket and Trim***

The dishwasher tub seal prevents water leakage. The seal is fitted in a seal channel that lines the rim of the dishwasher tub. To remove the tub seal or trim:

1. Open the dishwasher door.
2. Remove the dishwasher tub seal by grasping one end of the seal to peel it away from the seal channel.
3. Remove the 2 screws and then pull the trim straight up off the lip of the tub.



4. Reverse the above the steps to reinstall.

Note: When installing the tub seal, make sure it is seated properly in the seal channel. Run your finger over the seal to make sure it is smooth and even for a proper seal. A correctly installed gasket will have both ends of the gasket equal distance from the bottom of the tub.



## ***Air Breaker Assembly***

The air breaker assembly is mounted on the left side of the tub. Its purpose is to provide a method of supplying water for the wash and rinse cycles. The air gap prevents the dirty wash water from flowing back into the water supply system and prevents the water pressure from dropping to less than atmospheric pressure. The air breaker assembly also lets air into the tub to assist with drying. To remove the air breaker assembly:

1. Disconnect the power.
2. Remove the left side base panel.
3. Disconnect the wire harness from the air breaker assembly.



4. Open the door and rotate the air breaker nut and remove it from the air breaker assembly.
5. Remove the 4 clamps from the pipes. Note: Do not reuse the clamps when replacing the air breaker assembly. Replace them with new screw type hose clamps.



## **Nozzle Duct**

1. Disconnect the power
2. Open the door, remove the spray arm and the 2 screws on the lower spray panel.
3. Release the snap joints shown in the picture below then take out the nozzle duct and lower spray panel.



## **PCB**

The Printed Circuit Board is the center of the dishwasher. It receives and process the signal from components, sends commands to components and deals with the feedback information, etc. The PCB can be removed from the protecting box at the bottom of the machine. To remove the PCB:

1. Disconnect the power.
2. Take out the cutlery basket, racks and filter system.
3. Lay the dishwasher on its back.
4. Remove the 2 screws from the kick plate and 2 screws from the insulating panel.
5. Remove the 1 screw on the PCB control box.



6. Remove the 2 snap fittings that attach the PCB to the control box.
7. Disconnect the wire connections and replace the PCB.



### ***Water Inlet Valve***

The water inlet valve is electronically controlled and solenoid-operated. The water valve has an approximate resistance value of 1 K $\Omega$ . The water valve is mounted on a bracket located on the left side of the front brace. To remove the water valve:

1. Disconnect the power.
2. Remove the 2 screws from the kick plate and the 2 screws from the insulating panel.

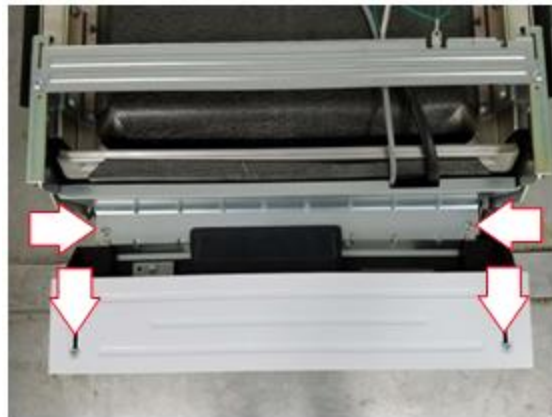

3. Remove the 90° elbow for the water line.
4. Remove the side plate.

5. Carefully remove the 2 screws that hold the water valve to the front brace – do not strip the screws.
6. Remove the plastic bracket for the valve like pictured below.



7. Disconnect the wire from the solenoid.
8. Remove the clamp and outlet hose from the valve.

Note: Do not reuse the clamp when replacing the air breaker assembly. Replace it with a new screw type hose clamp.

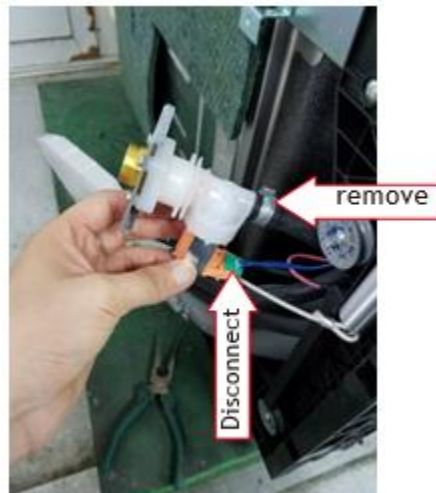

### ***Pressure Switch***

The pressure switch is an overflow safety device mounted to the base and located at the right rear. A clear plastic tube (the pressure switch hose) runs from the pressure switch, around the air breaker assembly and to the sump. As the dishwasher basin fills with water, the air pressure in the pressure switch hose increases. Normally, the electronic control regulates the amount of time the water fill valve remains open. If the water fill valve remains energized, the basin will overflow and increase the air pressure in the pressure switch hose causing the pressure switch to open the circuit to the water valve and energize the drain pump.



To remove the pressure switch:

1. Disconnect the power and lay the dishwasher on its back.
2. Remove the 1 screw that attaches the base cover to the base, then use a flat-head screw driver to release the snap joints.
3. Remove the wiring harness connected to the float switch on the base cover.
4. Release the snap joint (using a flat-head screwdriver) that attaches the pressure switch to the base, and remove the pressure switch.

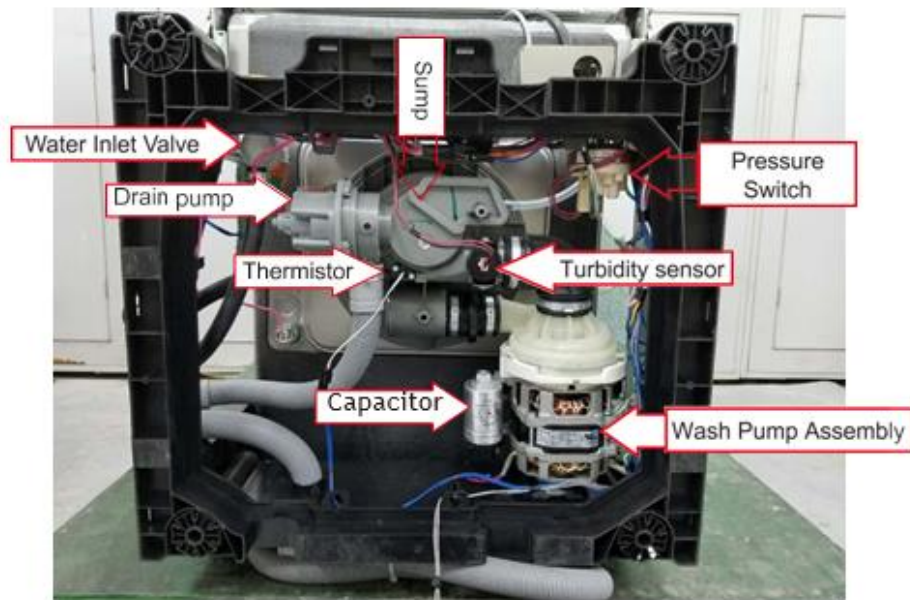

5. Disconnect the brown wire from terminal 1 and the red wire from terminal 2.
6. Remove the pressure switch hose from the pressure switch.



Note: When reinstalling the pressure switch, ensure the switch is fully seated in the bottom of the base bracket.

## ***Drain Pump Assembly***

The drain pump assembly is located under the tub and operates on 120 VAC. It is energized for the first 60 seconds of a new cycle and 90 seconds after the wash pump shuts down to remove any water in the dishwasher sump. The drain pump forces water out of the drain line. A check valve flapper on the drain pump prevents dirty water from reentering the sump. The drain pump has an approximate resistance value of 25- 35Ω. To remove the drain pump:

1. Disconnect the power.
2. Open the dishwasher door and remove the bottom rack.
3. Lay the dishwasher on its back
4. Remove the 1 screw that attaches the base cover to the base, then use a flat-head screw driver to release the snap joints.
5. Remove the wiring harness connected to the float switch on the base cover.
6. Rotate the drain pump ¼ turn counterclockwise to remove, which is the opposite direction of the mark on the sump.
7. Disconnect the 2 wires from the drain pump.

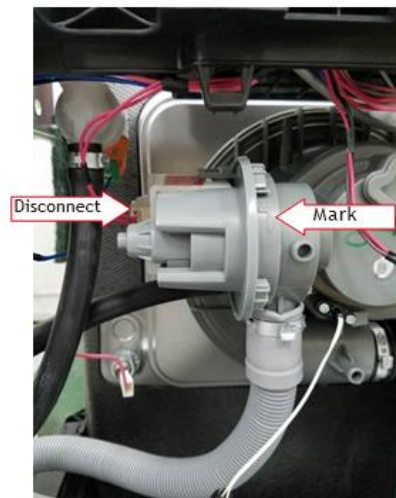
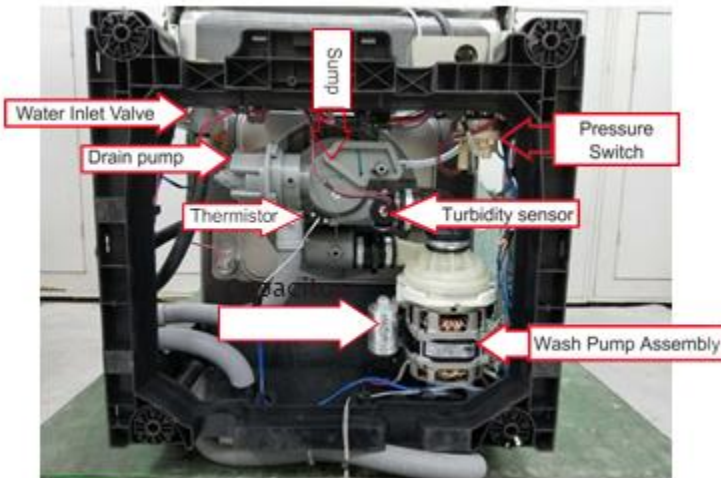

Note: Ensure the O-ring is retained in the pump seal before reassembly.

## ***Thermistor***

The thermistor is located under the tub and is attached to the back side of the sump with two screws. During the hot wash cycle, the thermistor senses the water temperature and turns the heating element off. The thermistor has a negative coefficient. As the temperature at the contact point on the tub increases, the thermistor's resistance decreases. The thermistor has an approximate resistance of  $R@25^{\circ}\text{C}=10\Omega\pm 2\%$ ;  $R@60^{\circ}\text{C}=3011\Omega\pm 2\%$ .

Note: If the thermistor is not operating, the hot wash cycle will set a default time for the heating element to cycle.

To remove the thermistor:

1. Disconnect the power.
2. Lay the dishwasher on its back.
3. Remove the 1 screw that attaches the base cover to the base, then use a flat-head screw driver to release the snap joints.
4. Remove the wiring harness connected to the float switch on the base cover.
5. Disconnect the thermistor wire harness.
6. Remove the 2 screws and the thermistor from the sump.

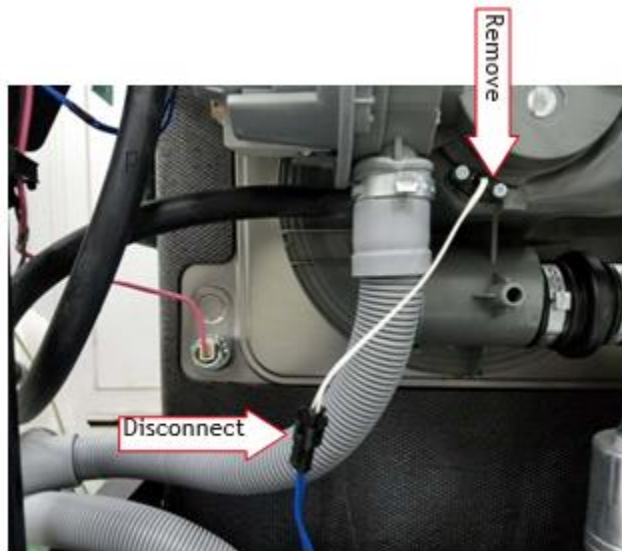

Note: Ensure that the O-ring is retained in the thermistor before reassembly.

### ***Turbidity Sensor***

The turbidity sensor is located under the tub and is attached to the back side of the sump with two snap joints. During the pre-wash of wash cycle, the turbidity sensor senses the water, judges the AD interval and chooses the appropriate wash cycle.

Note: If the turbidity sensor is not operating, wash dishwasher will choose a default wash cycle and inlet default wash water.

To remove the turbidity sensor:

1. Disconnect the power.
2. Lay the dishwasher on its back.
3. Remove the 1 screw that attaches the base cover to the base, then use a flat-head screw driver to release the snap joints.

4. Remove the wiring harness connected to the float switch on the base cover.
5. Disconnect the turbidity sensor wire harness.
6. Release the snap joints to remove the turbidity sensor.

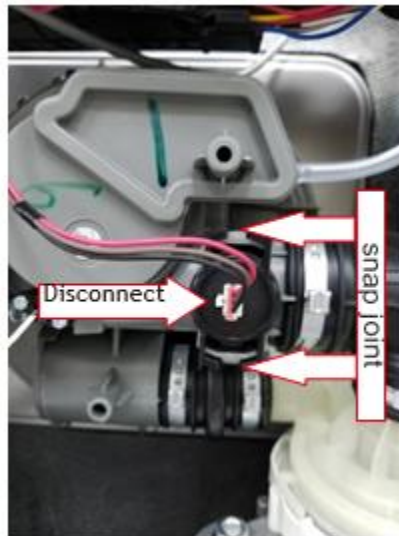

Note: Ensure the 0-ring is retained in the turbidity sensor before reassembly.

### ***Heating Element***

The heating element maintains water temperature during the wash and rinse cycles and heats the air during the drying cycle. To remove the heating element:

1. Disconnect the power.
2. Open the dishwasher door and remove the bottom rack.
3. Lay the dishwasher on its back.
4. Remove the 1 screw that attaches the base cover to the base, then use a flat-head screw driver to release the snap joints.
5. Remove the wiring harness connected to the float switch on the base cover.
6. Remove the 2 wires from the heating element.





7. Remove the two nuts and washers that attach the heating element to the bottom of the tub.



8. Lift the backside of the heating element and release it from the 2 retainers.



### ***Wash Pump Assembly (Pump and Motor)***

The wash pump assembly is located under the tub on the right of the sump assembly. The motor utilizes a start capacitor rated at 10 $\mu$ fd. The motor rotates clockwise (as viewed from the terminal end) and draws approximately 1 amp at 120 VAC. The motor has an approximate resistance of R1=24-30 $\Omega$  and R2=19-25  $\Omega$

To remove the wash pump assembly:

1. Disconnect the power.
2. Open the dishwasher door and remove the bottom rack.
3. Lay the dishwasher on its back.
4. Remove the 1 screw that attaches the base cover to the base, then use a flat-head screw driver to release the snap joints.
5. Remove the wiring harness connected to the float switch on the base cover.

6. Remove clamps and pump outlet hose.
7. Remove clamps and pump inlet hose.
8. Disconnect the motor wire harness, the motor ground wire and rubber bracket.

Note: Factory-installed hose clamps are not reusable. Replace the old clamps with new screw type hose clamps.

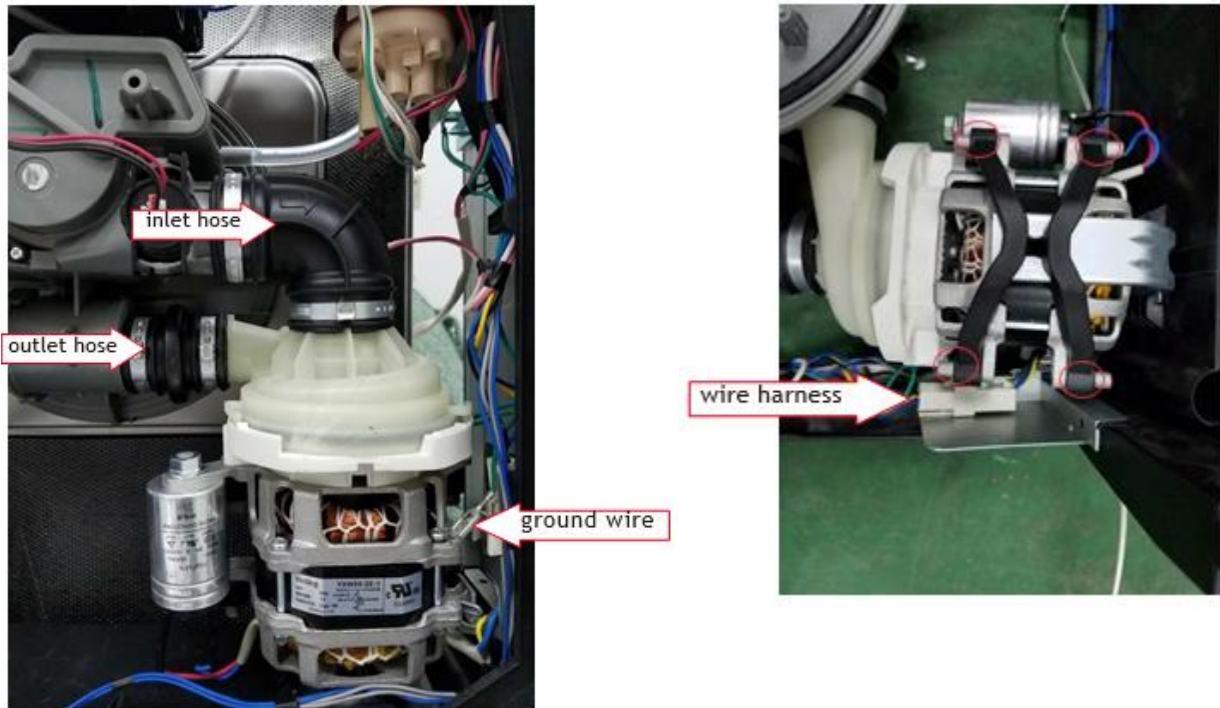

To remove the motor capacitor:

1. Follow steps 1 through 3 above.
2. The capacitor is connected to the motor with 2 wires and held in place with a nut. Disconnect the wires and the nut.

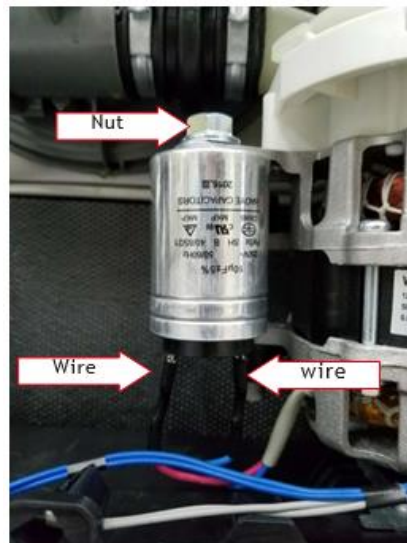

## Sump Assembly

The sump assembly consists of the filter assembly, micro-filter, connecting pipe, sump gasket and sump. The filter assembly prevents large particles from reaching the micro-filter, and the micro-filter prevents small particles from reaching the sump. The filter assembly rests above the sump and the micro-filter sits above the sump basin. The screws hold the sump gasket and sump to the bottom of the dishwasher. The gasket and sump are located under the tub.

To remove the sump assembly:

1. Disconnect the power.
2. Open the dishwasher door and remove the bottom rack.
3. Rotate the cylindrical filter  $\frac{1}{4}$  turn in the direction shown on the filter.
4. Lift steel filter and cylindrical filter out of the tub.



5. Remove the lower spray arm.
6. Remove the 3 screws that attach the sump to the tub.
7. Remove the sump gasket and sump.
8. Lay the dishwasher on its back.
9. Remove the 1 screw that attaches the base cover to the base, then use a flat-head screw driver to release the snap joints.
10. Remove the wiring harness connected to the float switch on the base cover.
11. Disconnect the thermistor wire harness and turbidity sensor wire harness.



12. Remove the 2 clamps, outlet hose, and inlet hose to the sump.
13. Remove the drain pump from the sump.
14. Remove the inner drain pipe from the sump.

Note: Factory-installed hose clamps are not reusable. Replace the old clamps with new screw type hose clamps.

**Sump**

Front View



Rear View

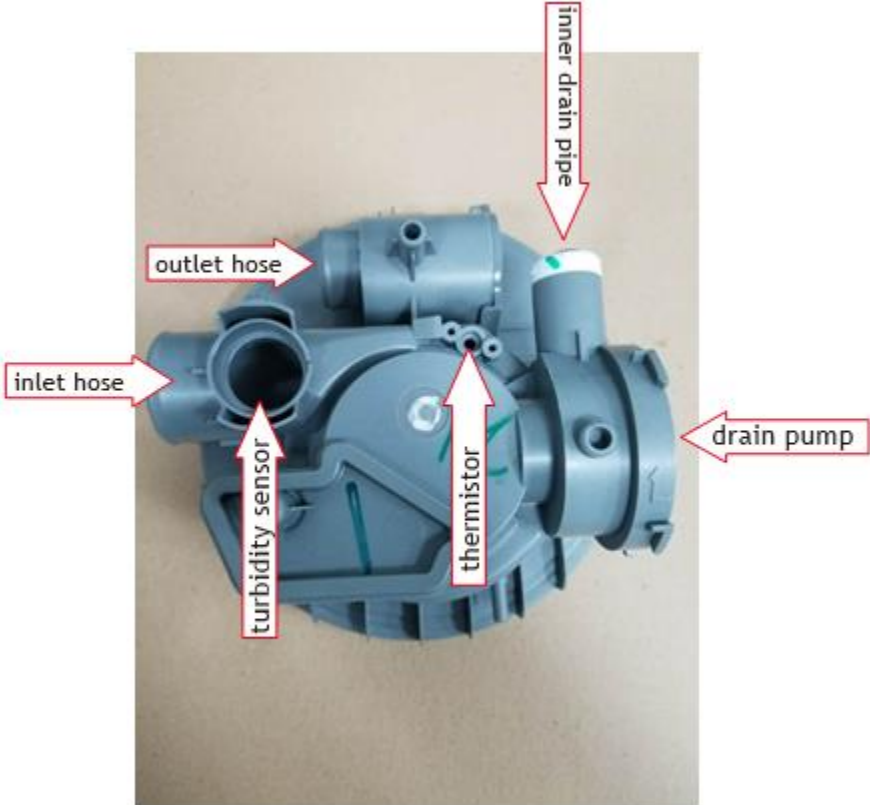

## Troubleshooting

### ***Factory Diagnostic Mode***

To enter the factory diagnostic mode:

1. Turn the dishwasher off and make sure all LEDs are off.
2. Disconnect the power
3. Reapply power with the door open and press and hold both the Rinse and Start/Cancel button within 60 seconds. Close the door and the display will show each board type code and F\* (\* = 0,1,2) for 1 second. Then the dishwasher will run the factory diagnostic mode as shown below.

No.	Component	Display	Note
01	Wash Pump Impeller	Turbidity	Turns on water inlet and impeller then after 10 seconds turn off the fan. The flow meter will control the water inlet to let in 3L water. This step has turbidity detection function the SSD will the turbidity value.
02	Heating Element	04 / Water Temperature	Turns on the wash pump then after 10 seconds, the heater will turn on. The unit will beep one time when the temperature has risen 3~5 degrees for the first time. The dishwasher will stop when the temperature has arrived at 135°F (57°C). Press "start/cancel" to enter the next step.
03	High Wash Pump Dispenser	03	Turns on wash pump for 8 seconds after a 2 second delay, then turns on the dispenser for 45 seconds.
04	Pause	02	Pauses for 30 seconds.
05	Drain Pump	01	Turns on the drain pump for 30 seconds.
06	End	Board Type Code and F*	Beeps one time. The SSD will show the board type code and F* (* = 0,1,2). Restart the dishwasher to enter standby mode.

## Error Codes

Code	Error	Possible Reason
E1	During the water inlet step, if the flow meter does not detect the correct amount of water after 4 minutes the E1 code will be displayed.	<ol style="list-style-type: none"> <li>1. Check the water supply</li> <li>2. Check the inlet valve</li> <li>3. Check the inlet line</li> <li>4. Check the flow meter</li> <li>5. Check the pressure switch</li> <li>6. Check the drain</li> <li>7. Check the PCB</li> </ol>
E3	(Only displayed in factory diagnostic mode) When the proper temperature is not reached after 90 minutes the E3 code will be displayed.	<ol style="list-style-type: none"> <li>1. Check the heater</li> <li>2. Check the thermistor</li> <li>3. Check the PCB</li> </ol>
E4	Water leak detected and E4 code displayed.	<ol style="list-style-type: none"> <li>1. Check the amount of detergent used</li> <li>2. Make sure unit is level</li> <li>3. Check the float switch</li> <li>4. Check the drain pump</li> <li>5. Check the amount of water being let in</li> <li>6. Find the leak location</li> </ol>
E6 E7	(Only displayed in factory diagnostic mode) E6 – Thermal Sensor Open. E7 – Thermal Sensor Short.	<ol style="list-style-type: none"> <li>1. Check the water inlet temperature</li> <li>2. Check the thermistor</li> <li>3. Check the PCB</li> </ol>

## Exploded Views and Parts List

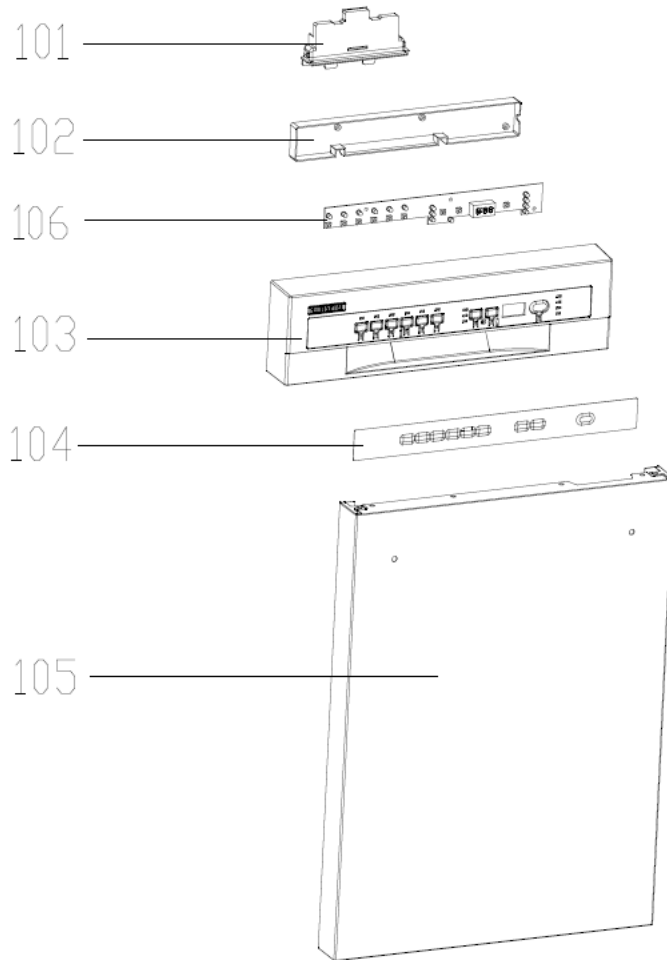

<b>NO.</b>	<b>Part No.</b>	<b>Description</b>	<b>Qty.</b>
101	1217600002346	Handle Cover	1
102	12176000022486	Panel Cover	1
103	12176000022484	Control Panel	1
104	12176000022489	Control Panel Patch	1
105	12276000006494	Outer Door	1
106	17176000021062	Display Circuit Board	1

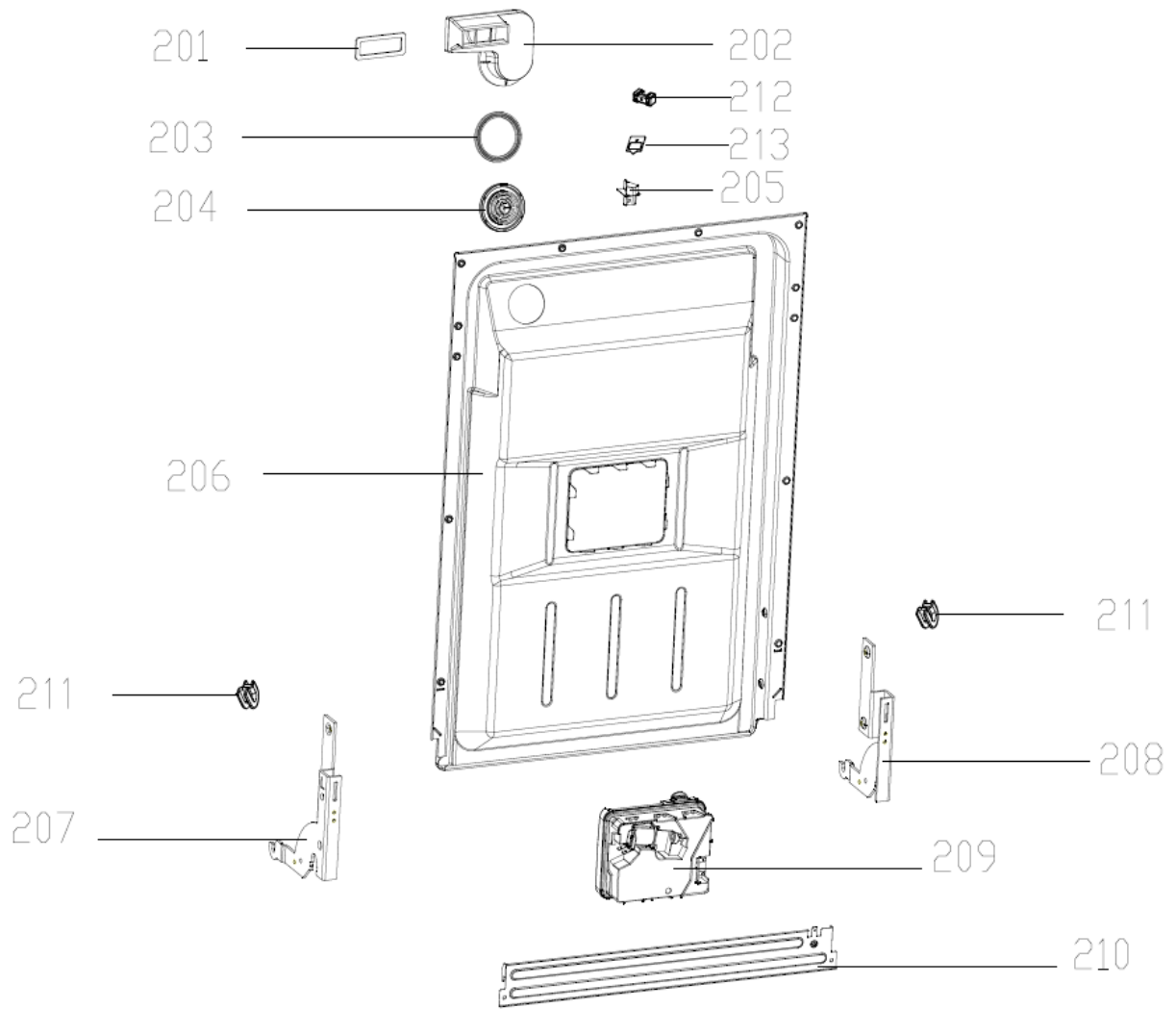

NO.	Part No.	Description	Qty.
201	12676000003401	Sealing Gasket	1
202	12176000022487	Transom	1
203	12676000000744	Sealing Ring	1
204	12176000022490	Plastic Nut	1
205	12176000009495	Door Lock Hook	1
206	12276000012581	Inner Door Assembly	1
207	12276000001731	Left Hinge Assembly	1
208	12276000001778	Righ Thinge Assembly	1
209	17476000007262	Dispenser	1
210	12276000001810	Hinge Join Board	1
211	12176000003629	Snap Ring	2
212	12176000008565	Lock Buckle Fixing Block	1
213	12676000001038	Waterproof Silicone Pad	1



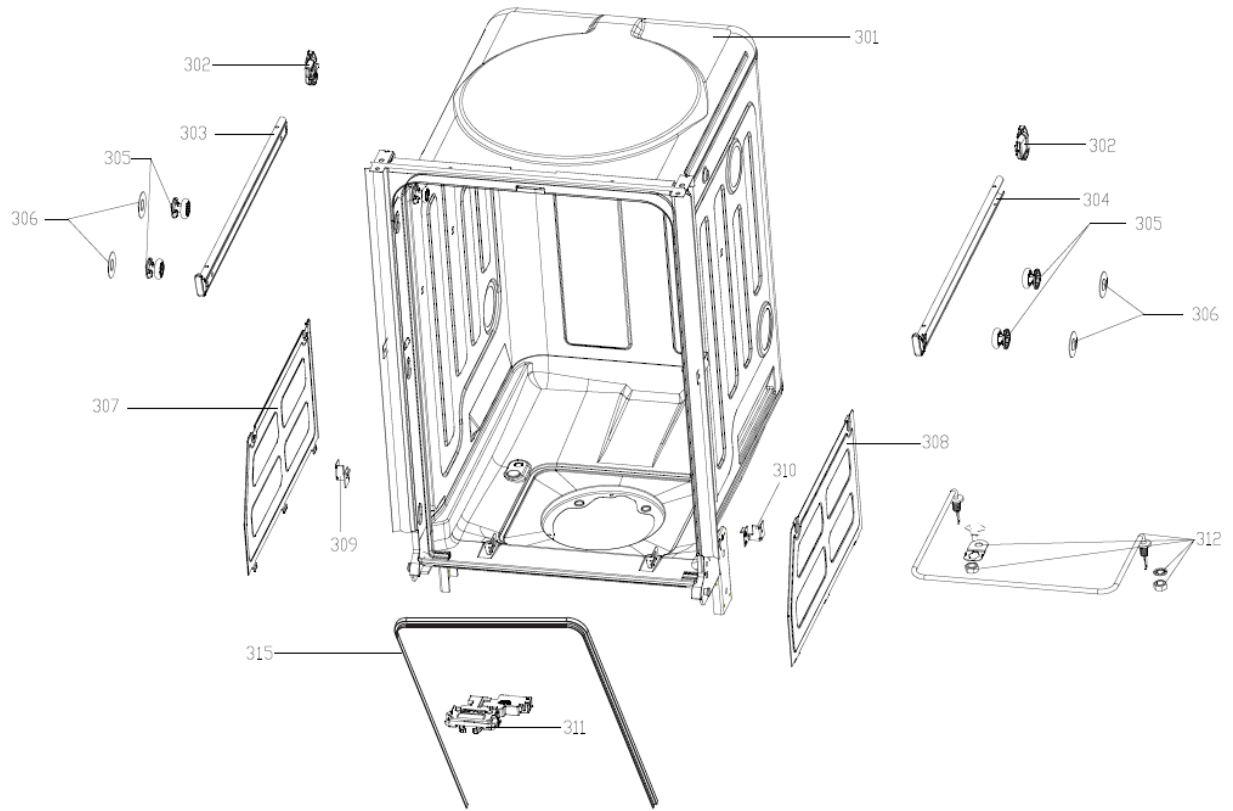

NO.	Part No.	Description	Qty.
301	12276000012578	Tub Assembly	1
302	12176000008496	Stopper	2
303	12276000001357	Upper Basket Guider (Left)	1
304	12276000001360	Upper Basket Guider (Right)	1
305	12176000010412	Rail Support Assembly	4
306	12176000008573	Basket Guider Supporting Holder	4
307	12276000012470	Connecting Board	1
308	12276000012465	Connecting Board	1
309	12276000012467	Metal Bracket	1
310	12276000012468	Metal Bracket	1
311	17476000000035	Door Swieth Assembly	1
312	17476000007223	Heating Elements	1
315	12676000003841	Weatherstrip	1

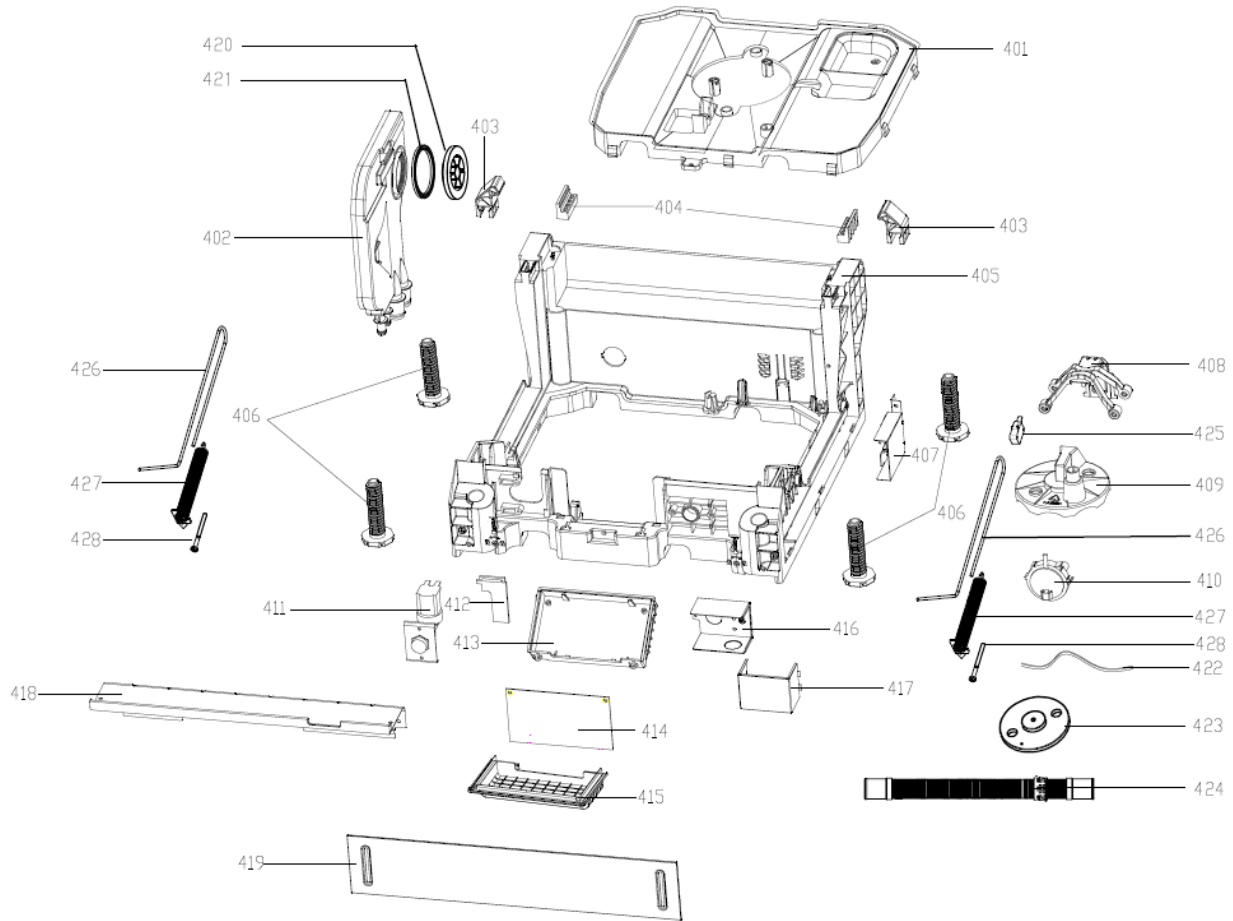

NO.	Part No.	Description	Qty.
401	12176000022349	Base Tray Cover	1
402	12176000022483	Air Breather	1
403	12176000008440	Tub Connecting Block	2
404	12176000008598	Tub Support	2
405	12176000022348	Base Tray Assembly	1
406	12176000009726	Foot	4
407	12276000012469	Metal Bracket	1
408	12276000008925	Pump Support Assembly	1
409	12176000022347	Float Seat	1
410	17476000007426	Pressure Switch	1
411	17476000007222	Inlet Valve	1
412	12176000022345	Block	1
413	12176000022344	PCB Box	1
414	17176000021065	Master Board	1
415	12176000022346	PCB Box Cover	1
416	12276000001798	Junction Box A	1
417	12276000001800	Junction Box B	1
418	12276000012471	Acoustic Panel	1
419	12276000012466	Adjustable Baseboard	1
420	12176000013663	Air Breather Nut	1
421	12676000000713	Washers	1
422	12676000000651	Pressure Switch Pvc Pipe	1
423	12876000000050	Float	1
424	12676000000138	Drain Pipe Assembly	1
425	17476000001137	Microswitch	1
426	12976000000392	Door Rope	2
427	12976000000133	Spring	2
428	12976000001001	Adjust Screw Of Door Spring	2

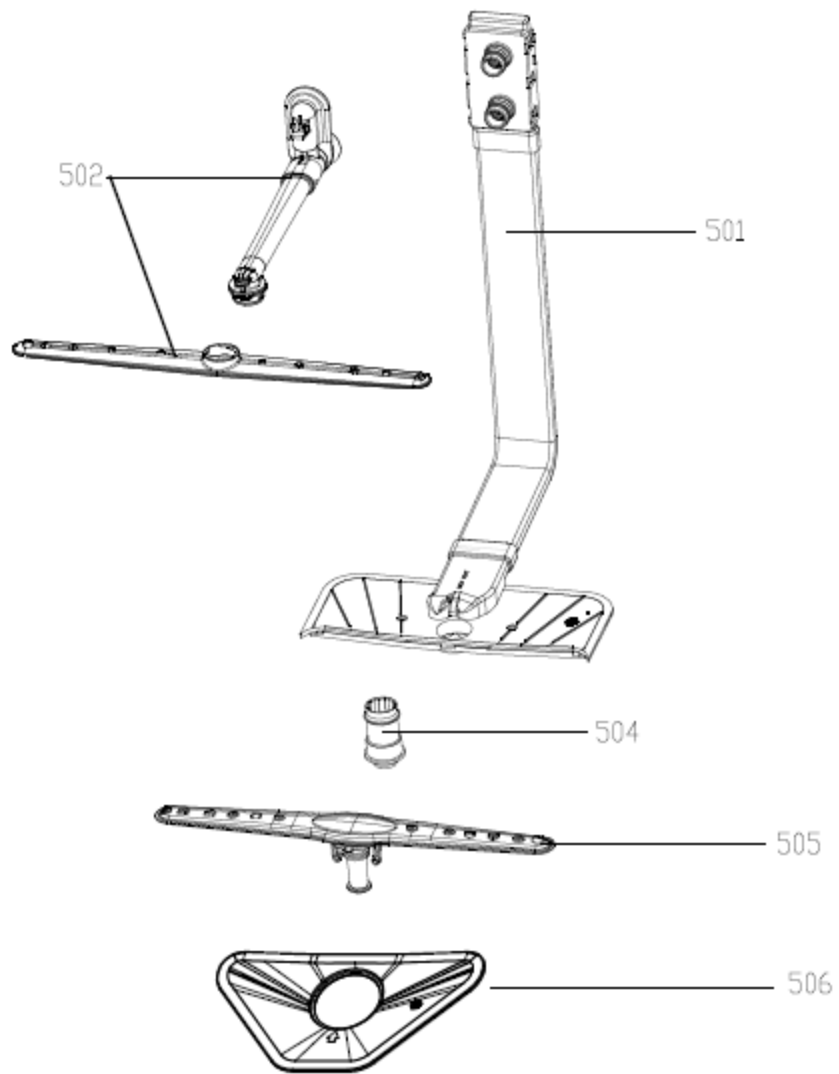

NO.	Part No.	Description	Qty.
501	12176000009430	Inner Pipe Assembly	1
502	12176000022224	Upper Sprayer Assembly	1
504	12176000008645	Lower Sprayer Seat	1
505	12276000012606	Lower Sprayer	1
506	12176000003689	Plane Filter	1

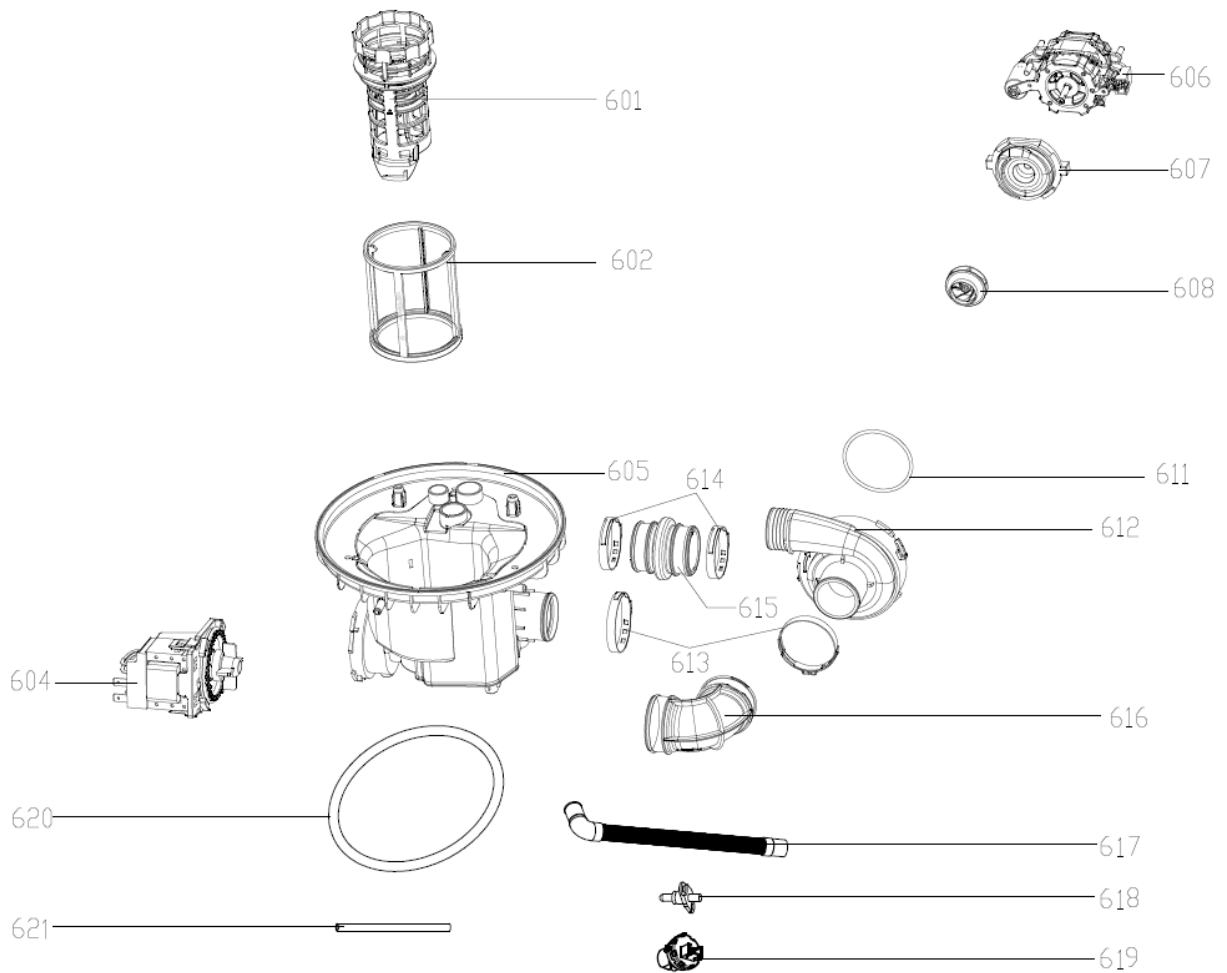

NO.	Part No.	Description	Qty.
601	12176000018543	Filter Handle	1
602	12176000003676	Cylindrical Filter	1
604	11001011001029	Permanent Magnet Synchronous Pump	1
605	12176000016230	Water Cup Assembly	1
606	11002012028203	Single Phase Asynchronous Motor	1
607	12176000002603	Lower Pump Case	1
608	12176000008776	Impeller	1
611	12676000000780	Pump Sealing Ring	1
612	12176000022488	Upper Pump Case	1
613	12976000000308	Clamp	2
614	12976000004604	Clamp	2
615	12676000000146	Outlet Pipe	1
616	12676000000100	Inlet Pipe	1
617	12676000004602	Drain Hose	1
618	17176000000297	Sensor Assembly	1
619	17176000014521	Turbidity Sensor	1
620	12676000001461	Sealing Ring	1
621	12676000000188	Inlet Pipe	2

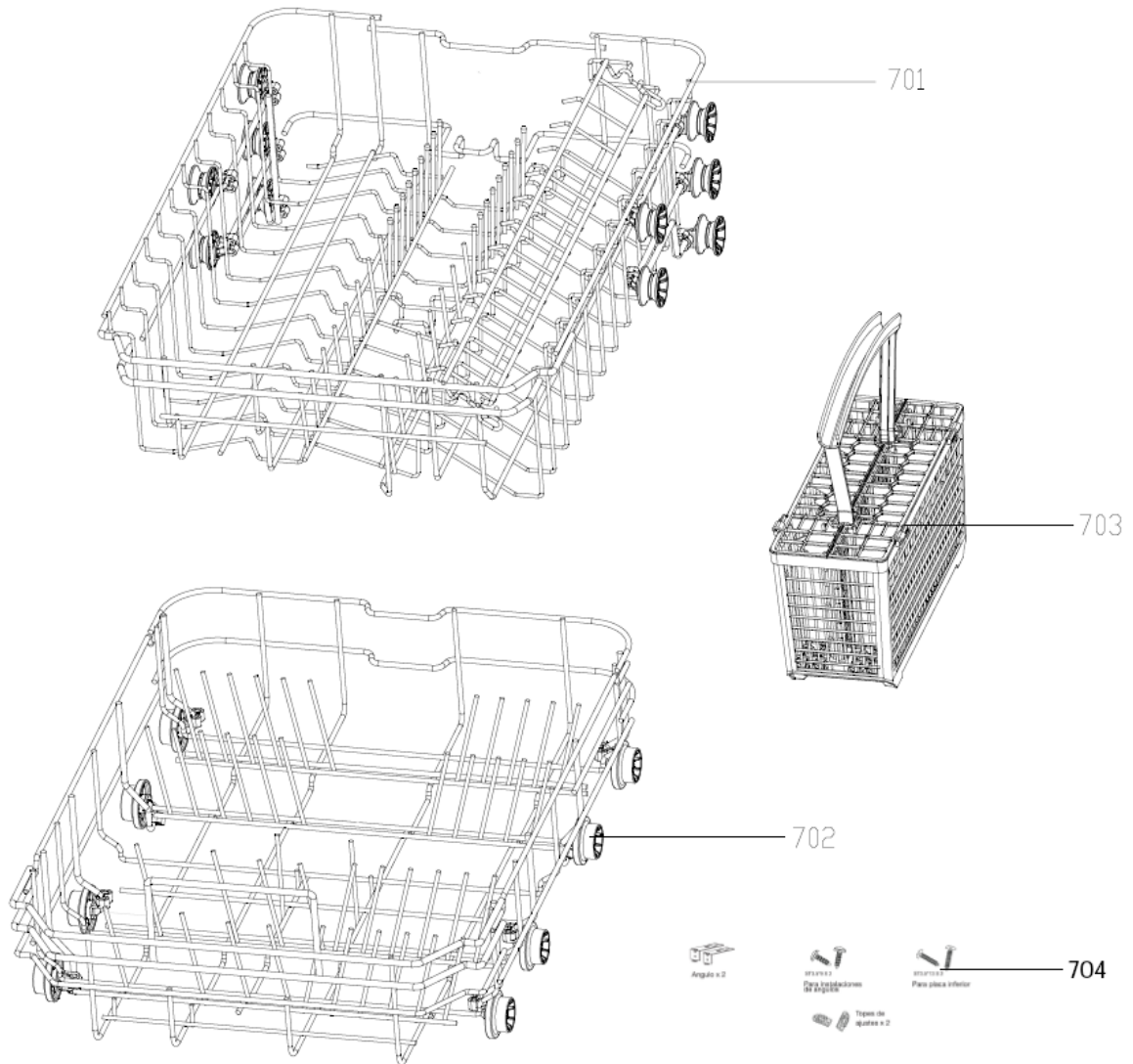

NO.	Part No.	Description	Qty.
701	12976000004284	Upper Basket Assembly	1
702	12976000004287	Lower Basket Assembly	1
703	12176000002753	Cutlery Basket	1
704	12976000004444	Accessory Bag	1
	121760000008811	wheels for upper Basket	1
	121760000008775	wheels for lower Basket	1

# Wiring Diagram

WARNING: Disconnect electrical power before servicing.

Caution: Label or take pictures of all wires prior to disconnection. Wiring errors can cause improper and dangerous operation. Verify operation after servicing.

110-127V/60Hz

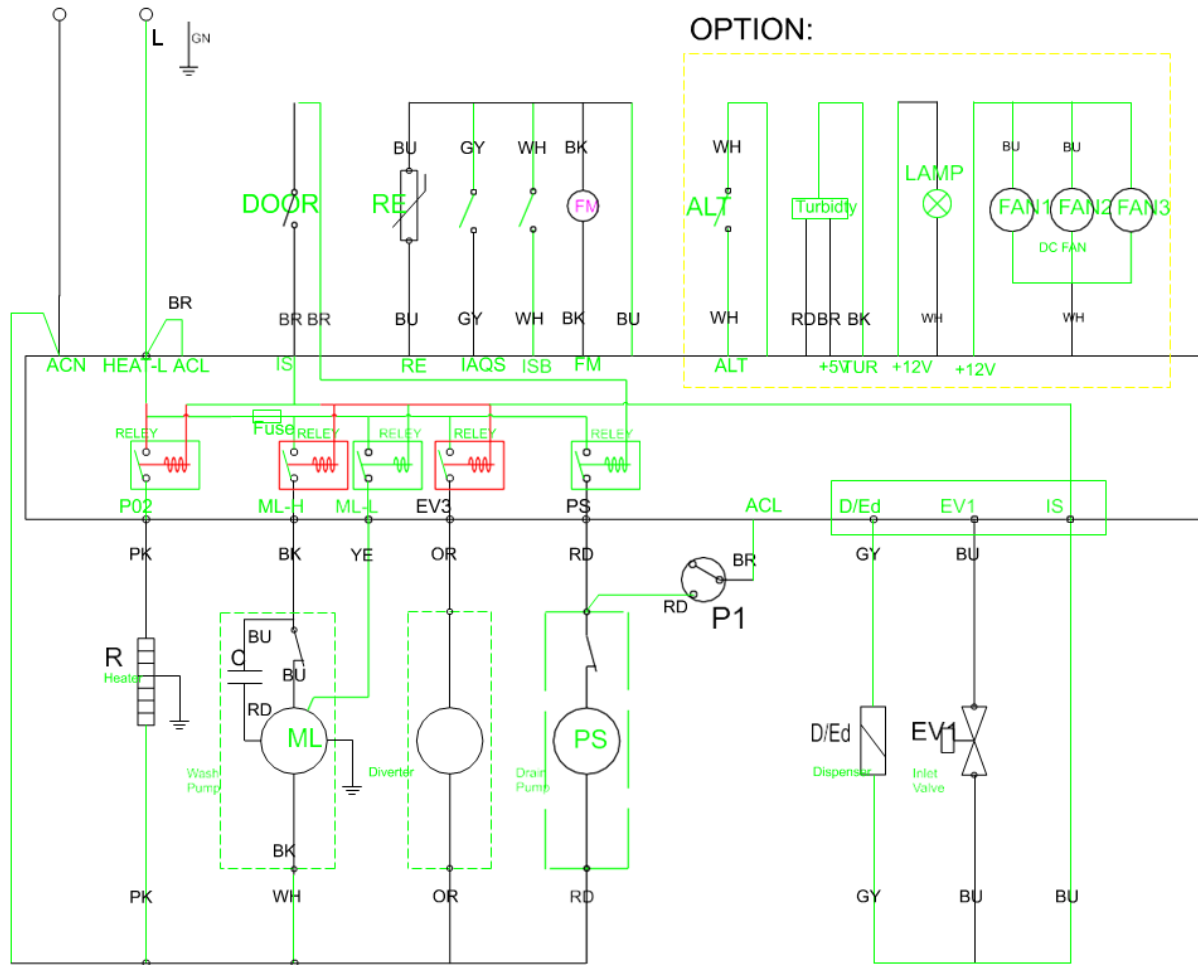

Code	Designation	Code	Designation	Code	Designation
ACL	Live(Alternating Current)	ISS	Salt Detector	BU	Blue
ACN	Neutral (Alternating Current)	ML	Wash Pump	YE	Yellow
	Ground		Capacitor	GN	Green
D/Ed	Dispenser	PS	Drain Pump	WH	White
EV1	Inlet Valve	FAN	Fan	RD	Red
EV3	Water Diverter	FUSE	Fuse(3.15A)	BK	Black
IAQS	Overflow Switch	R	Heater	PK	Pink
FM	Flow Meter	DOOR	Door Switch	GY	Gray
P2	Dry Heating Protect Switch	IS	Door Switch Detector	OR	Orange
P1	Water Level Switch (140/120)	RE	Temperature sensor(NTC)	BR	Brown
ISB	Rinse Aid Detector	NS	Nephelometer / Turbidity Sensor	PU	Purple

<b>DATE</b>	<b>REVISION NOTES</b>
2/4/2019	INITIAL DOCUMENT