



CWR265SZ

26 Bottle Built-in Wine Cooler

Owner's Manual

This owner's manual provides instructions on safe installation use, and troubleshooting assistance. Please read it carefully and save it for reference



<http://www.edgestar.com>

Important Safeguards

When using an electrical appliance, basic precautions should always be followed, including the following:

Before use, please read and follow all instructions

- Do not use if the power supply cord is damaged. If damaged, it must be replaced by the manufacturer or a similarly qualified person.
- This wine cooler is not intended for use by young children or infirm persons without supervision. Young children must be supervised to ensure they do not play with the appliance.
- Ensure the cooler is unplugged before cleaning or if not in use.
- To clean the cooler use only mild detergents or glass cleaning products. Never use harsh detergents or solvents.
- It is not recommended to use this wine cooler with an extension cord or power strip. Please ensure that the appliance is plugged directly into the electrical outlet.
- This cooler is designed to store wine bottles. If food is placed inside, ensure that there is sufficient airflow between items. Also note that the temperature range for this cooler is optimized for wine and beverage storage. Perishable food items may require a different storage environment.
- Do not place hot food or drinks into the wine cooler before they cool down to room temperature.
- Close the cooler door immediately after putting in any items so the inside temperature will not rise dramatically.
- Avoid subjecting the cooler to external heat sources or direct sunlight.
- For a stable installation, make sure the cooler is placed on a flat, level, and solid surface.
- Make sure that the surface on which the wine cooler is placed is strong enough to hold the wine cooler once it is fully loaded with wine bottles.
- Do not place any other appliances on top of the wine cooler.
- The wine cooler is an electrical appliance. To avoid injury or death from electrical shock, do not operate the wine cooler with wet hands, while standing on a wet surface, or while standing in water.
- Do not use outdoors or in wet or moist conditions.
- Do not turn the cooler upside down, on its side, or 45° or more off level.
- Never pull the power cord to disconnect it from the outlet. Grasp the plug and pull it from the outlet.
- Never lift or carry the wine cooler by the power cord.
- Keep the power cord away from heated surfaces.
- This wine cooler is designed for household, non-commercial use only.
- Do not plug this cooler into the power socket before set up is completed.
- An empty cooler can be dangerous for children. If disposing of the cooler remove gaskets, latches, lids and the entire door from your unused appliance, or take other action to ensure that children cannot become trapped inside.
- If your model of wine cooler is equipped with a lock, take care to keep the keys away from children.
- Do not cut or remove the third prong (the grounding prong) from the power cord.
- The cord should be secured behind the unit and should not be left exposed or dangling.

Do not move this cooler without emptying it of its contents and securing the door in a closed position.

Table of Contents

Important Safeguards	1
Specifications	3
Parts Identification	4
Installation	5
Operation.....	5
Temperature Control	6
Rack Removing and Insertion	7
How to remove a rack:	7
How to insert a rack:	7
Troubleshooting.....	8
EdgeStar Limited Warranty	10

First Time Operating Instructions

Before use, make sure all packaging labels and materials are all removed from the unit. Be sure to keep track of all included parts and pieces before discarding packaging materials. It is advised that you keep the original box and packing materials in case you are ever to move or ship the unit in the future.

Let the unit stand for at least 24 hours before use; this allows the cooling components to settle from transit. The instruction manual should be thoroughly read before use.

Specifications

Model Number	CWR265SZ
Capacity	26 Bottles
Input Power	120W
Rated Frequency	60Hz
Power Consumption	1.8kw.h/24h
Cooling System	R134a
Ambient Temp	60 - 90°F
Temperature Range	50 - 56°F
Rated Voltage	115V
Weight	95 Lbs
Dimensions (HxWxD)	34.4"x15.0"x22.6"

Parts Identification

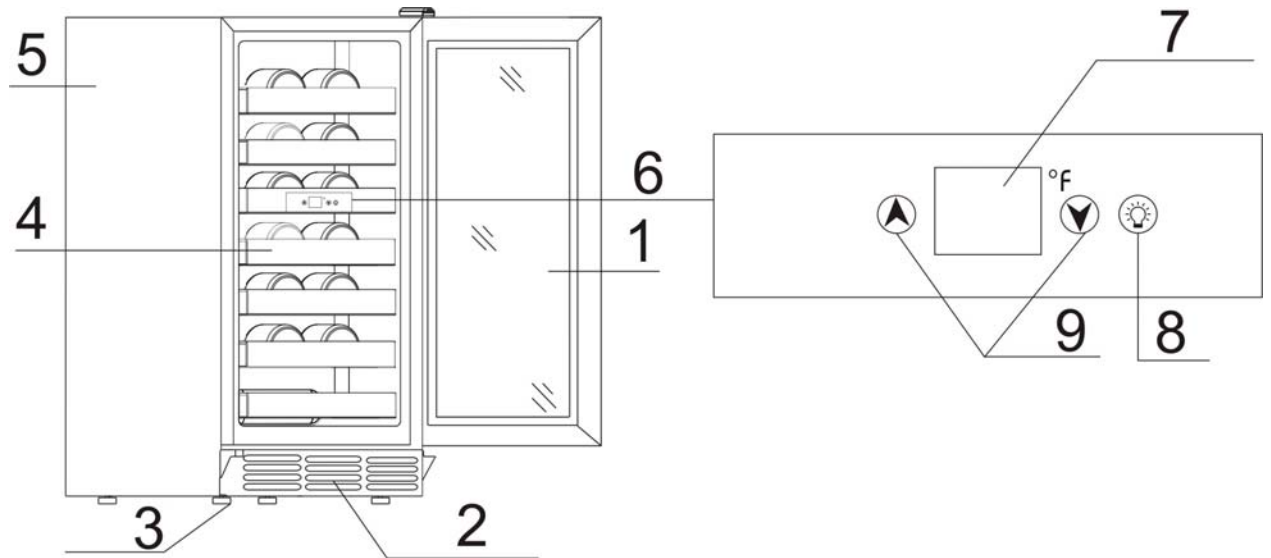

Important Note: Even if your refrigerator looks slightly different; the operation will essentially be the same. Picture is provided for reference.

- 1 Dual-pane window
- 2 Front grill
- 3 Adjustable legs
- 4 Main shelving
- 5 Cabinet
- 6 Main control panel
- 7 Temperature indicator
- 8 Light switch
- 9 Temperature adjustment buttons

Installation

- Clear unit of any loose packaging materials.
- Confirm you have all required loose parts and pieces.
- Place the unit on a flat, dry surface that is able to support the unit while fully loaded.
- This unit is designed to be either recessed or free standing.
- Avoid placing heavy objects on top of the unit.
- The unit is not designed for use in a basement or garage.
- The unit is not designed to be in direct sunlight or near sources of heat.
- Avoid placement near other heat-emitting appliances.
- Do not share outlets with other powerful appliances.
- Let stand for at least 24 hours before powering up to let cooling materials settle.
- Gently clean the unit's interior surface with warm water, using a soft cloth before first use.

Operation

1. Insert racks into unit.
2. Adjust temperature.
3. Place bottles to be cooled inside unit.
4. Plug the power cord into a standard grounded electrical outlet.
5. Keep door closed to keep optimal temperature and conserve energy.
6. Toggle the internal light by pressing the button on the front control panel.

Important Note: Allow at least 24 hours for the internal temperature to become adjusted properly before first use.

Temperature Control

Front panel controls

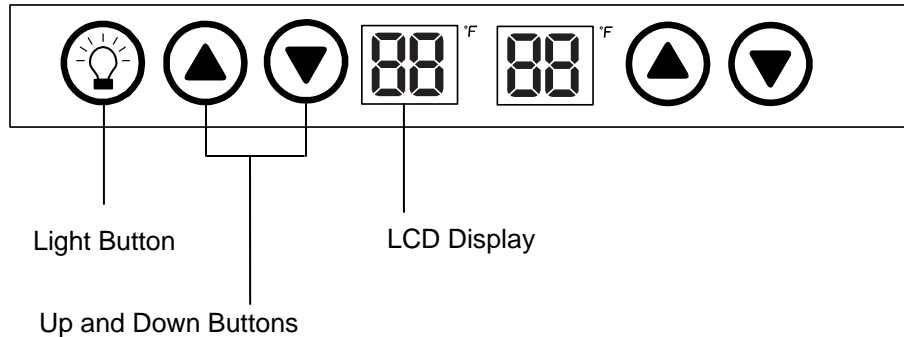

Using the controls:

Use the left side controls to adjust the temperature. The temperature displayed will be in Fahrenheit. This wine cooler has an actual temperature range from 50°F to 56°F. Whether your wine cooler can reach the actual set temperature depends on the ambient environmental conditions.

Please note that the front panel controls will allow you to change the temperature to a range that is higher and lower than 50-56°F; however, the unit is designed to only achieve temperatures between 50-56°F.

Press the ▼ button on the left side of the control panel to lower the temperature by 1 degree increments. The set temperature will flash for a few seconds, and then revert to the ambient inner temperature of the wine cooler.

Allow at least 24 hours for the temperature to acclimate, and before storing your wines.

Press the ▲ button on the left side of the control panel to increase the temperature by 1 degree increments.

Press the  button to turn on and off the inner light.

When the temperature of the unit becomes too low, the LED will display “LL”, likewise, when the temperature is too high, it will display “HH”. The unit will display “ER” in the event of an error or power disruption.

Tip: To conserve energy, always set the display above 48; otherwise, the inner fans will run continuously.

Note: The right side controls will have little or no bearing on the inner temperature. It is recommended you set the right LCD at 55.

Important Note: This unit will operate best in a room with a temperature less than 90°F (32°C).

Rack Removing and Insertion

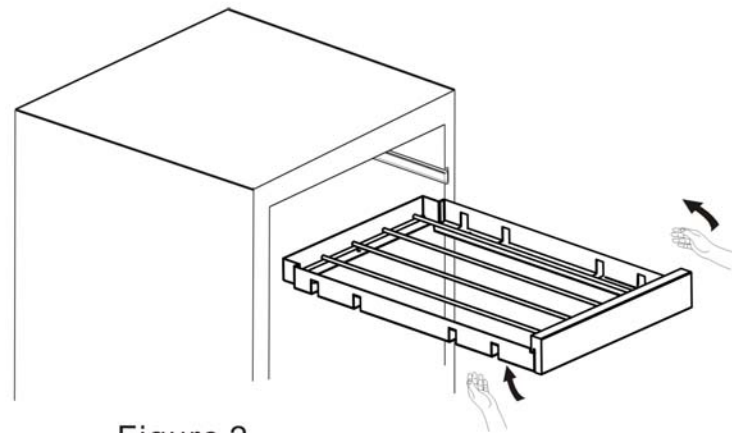
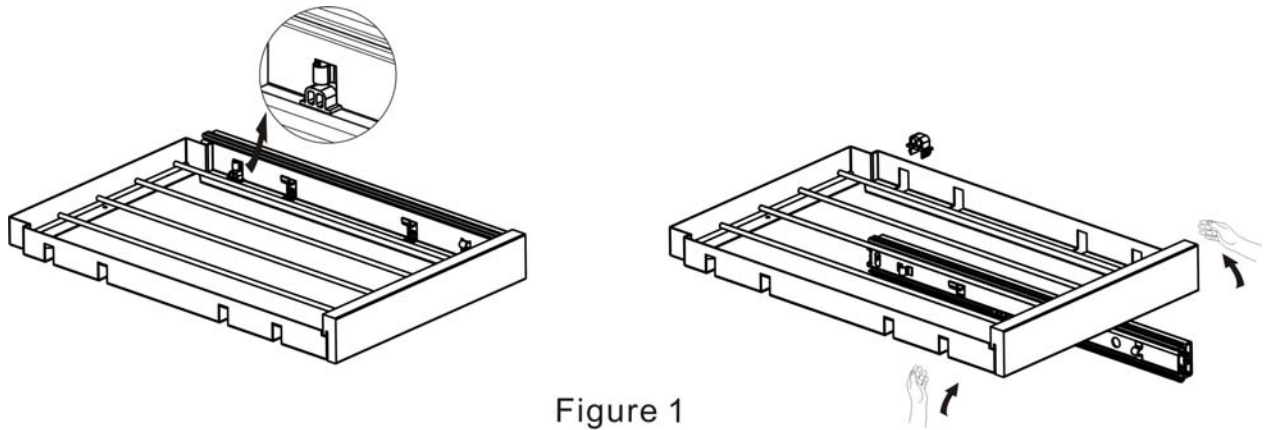

Be sure to have the door all the way opened when pulling shelves out of the rail compartment to avoid damage.

How to remove a rack:

1. Remove any bottles from the trays.
2. Remove the stopper from each side of the rack, and gently pull up. You can then remove the rack. (Fig. 1)

How to insert a rack:

1. Gently push the rack into the sliders. (Fig. 2)
2. Insert stopper to hold the rack into position.

Troubleshooting

Issue	Possible cause	Solution
The wine cooler does not turn on.	There is a power failure.	Ensure the cooler is plugged in and the power outlet has power.
	The cooler is not plugged in.	Plug the unit in to a power outlet that has sufficient amperage.
	A house fuse has blown or the circuit breaker is tripped.	Replace the broken fuse in your fuse box or reset the breaker.
The wine cooler will not reach the desired temperature	The cooler is placed too close to a heat source.	Keep the cooler away from sunshine or other heat sources.
	The cooler does not have sufficient ventilation.	Make sure the wine cooler has several inches of ventilation on the sides and back.
	The door is opened too frequently or for a long period of time.	Close the door tightly and do not open the door too frequently or for a long period of time.
I set the unit to 64°F, but it does not go to that temperature.	This is normal operation.	The unit will operate from 50°F to 56°F.
I set the unit to 48°F, and the unit runs all the time.	This is normal operation.	Set the temperature higher than 48°F. The unit will operate from 50°F to 56°F.
Frost is forming in the wine cooler	The environment is humid.	Though the unit uses an “auto-defrost” system, under certain conditions, manual defrosting may be required. If frost builds up, you can try running the cooler on a warmer temperature setting, minimizing the number of times you open the door, or unplugging the unit to allow the frost to melt.
	The ambient temperature is too low.	
	The door is being opened too frequently.	

Troubleshooting continued

Symptoms	Possible causes	Solutions
The cooler turns on and off frequently.	The room temperature is higher than the recommended ambient temperature (77°F).	Run the cooler in the appropriate ambient temperature.
	The door is being opened often.	Minimize the number of times the door is opened.
	The door is not completely closed.	Make sure the door is completely closed.
	The door gasket is not sealing properly.	Make sure the door gasket is properly sealing.
	The cooler does not have the suggested ventilation.	Make sure the cooler has at least 2" on the sides and 4" in the back for clearance.
The cooler makes too much noise.	If the noise is from the fan, it may be normal operating noise.	The fan makes normal fan noises when operating- this is normal.
	The unit is not level.	Make sure the cooler is on a level surface.
	Popping or crackling noises are coming from the unit.	Some popping or crackling noises are normal. They are caused by expansion and contraction of the inside walls due to temperature changes.
The door will not shut properly.	Your cooler is not level.	Make sure the cooler is on a level surface.
	The door gasket is dirty.	Clean the door gasket.
	The door gasket is malformed.	Make sure the door gasket is properly sealing.
	The shelves are incorrectly installed.	Correctly install the shelves.

EdgeStar Limited Warranty

One (1) Year Parts & Ninety (90) Days Labor

This product is warranted by EdgeStar to be free from defective workmanship and materials, subject to any conditions set forth as follows:

WHAT IS COVERED:

LABOR: For a period of NINETY (90) DAYS from the date of original purchase, labor will be performed free of charge at an authorized EdgeStar repair facility. At its option, EdgeStar will repair the product with new or remanufactured parts, or exchange the defective product with a new, refurbished, or remanufactured product. If a product is replaced, it will carry the remaining warranty of the original product. After the ninety (90) day period, EdgeStar will no longer be responsible for labor charges incurred. All defective products and parts covered by this warranty will be repaired or replaced on a mail-in basis to an EdgeStar authorized repair facility.

PARTS: For a period of ONE (1) YEAR from the date of original purchase, EdgeStar will supply new, rebuilt, or refurbished parts free of charge. EdgeStar may request a defective part be returned in exchange for the replacement part. All replacement parts or products will be new, remanufactured, or refurbished. All products and parts replaced by EdgeStar under warranty service become the property of EdgeStar.

This warranty applies to the original purchaser only, and only covers defects in workmanship experienced during operation of the product under normal service, maintenance, and usage conditions. This warranty applies to the purchase and use of this product in residential settings within the United States of America.

WHAT IS NOT COVERED:

The following limitations apply to the coverage of this warranty. This warranty does not cover:

- Labor charges for installation, setup or training to use the product.
- Shipping damage, and any damage caused by improper packaging for shipment to an authorized service center, and any damaged caused by improper voltage or any other misuse, including abnormal service, handling, or usage.
- Cosmetic damage such as scratches and dents.
- Normal wear and tear on parts or replacement of parts designed to be replaced, e.g. filters, cartridges, batteries.
- Service trips to deliver, pick-up, or repair, install the product, or to instruct in proper usage of the product.
- Damages or operating problems resulting from misuse, abuse, operation outside environmental specifications, uses contrary to instructions provided in the owner's manual, accidents, acts of God, vermin, fire, flood, improper installation, unauthorized service, maintenance negligence, unauthorized installation or modification, or commercial use.
- Labor charges incurred 91 days or more after the date of original purchase.
- The use of EdgeStar products in commercial settings.
- Optional accessories, attachments, and appearance items.
- Products that have been modified to perform outside of specifications without the prior written permission of EdgeStar.
- Products lost in shipment, or theft.
- Products sold AS IS or from an unauthorized reseller.
- Products that have had their serial numbers removed or defaced. Products with serial numbers that have been invalidated.

OBTAINING WARRANTY SERVICE:

If you believe your product is defective, contact EdgeStar Customer Support for troubleshooting assistance and warranty service at 1-866-319-5473. Please have your serial number and proof of purchase available. Once an EdgeStar authorized representative has confirmed that your product is defective and eligible for warranty service, the product must be returned to an EdgeStar repair facility. The purchaser is solely responsible for prepaying all shipping related costs to and from the repair facility. EdgeStar is not responsible for damage resulting from shipper mishandling or improper packaging. Do not return a defective product to the place of purchase. Products received without a return authorization number will be refused.

THIS WARRANTY IS IN LIEU OF ANY OTHER WARRANTY, EXPRESS OR IMPLIED, INCLUDING WITHOUT LIMITATION, ANY WARRANTY OF MERCHANTABILITY OR FITNESS FOR A PARTICULAR PURPOSE. TO THE EXTENT ANY IMPLIED WARRANTY IS REQUIRED BY LAW, IT IS LIMITED IN DURATION TO THE EXPRESS WARRANTY PERIOD ABOVE. NEITHER THE MANUFACTURER NOR ITS DISTRIBUTORS SHALL BE LIABLE FOR ANY INCIDENTAL, CONSEQUENTIAL, INDIRECT, SPECIAL, OR PUNITIVE DAMAGES OF ANY NATURE, INCLUDING WITHOUT LIMITATION, LOST REVENUES OR PROFITS, OR ANY OTHER DAMAGE WHETHER BASED IN CONTRACT, TORT, OR OTHERWISE. SOME STATES DO NOT ALLOW THE EXCLUSION OF INCIDENTAL OR CONSEQUENTIAL DAMAGES, SO THE ABOVE EXCLUSION MAY NOT APPLY TO YOU. THIS WARRANTY GIVES YOU SPECIFIC LEGAL RIGHTS. YOU MAY HAVE OTHER RIGHTS THAT VARY FROM STATE TO STATE.



EdgeStar Products
Box 81336
Austin, TX 78708-1336

Toll Free: 1-866-319-5473
Web: <http://www.edgestar.com>
E-mail: service@edgestar.com

Register your product, download owner's manuals, access additional troubleshooting resources, and obtain more information on other great EdgeStar products on the web at: **<http://www.edgestar.com>**

Product contents and specifications may change without notice.

Copyright © 2009 Living Direct, Inc.